

FEATURES

- Operates on international licensed and licence free radio telemetry bands.
 - Range:
 - X8100 – 433 MHz 2km in free space, 0.2 - 0.5km in buildings
 - X8100 – 458 MHz 20km in free space, 1 – 3km in buildings
 - X8100 – 868 MHz 10km in free space, 0.7 – 2km in buildings
 - X8100 – GSM World Wide GSM Mobile Phone Network
 - X8100 – LLM Leased Telephone Line
 - Type approved to ETSI 300-220, ETSI 300-113, ETSI 300-683, MPT1328, MPT1329, MPT1340, MPT1344
 - 8 to 128 Digital Inputs
 - 8 to 128 Digital Outputs, Voltage Free Contacts 30Vdc @ 1A
 - 2 to 128 Analogue Inputs 0-20mA (Standard), 0-10V, 0-500mV. (factory set option)
 - 2 to 128 Analogue Outputs 0-20mA (Standard), 0-10V, 0-500mV. (factory set option)
 - 1 Serial Output Port for SCADA System
 - DIN Rail Mounted
 - Powered from 24Vdc (Standard), 110Vac, 240Vac.
- Size: X8100 Control Module 160mm by 105mm by 60mm
X8100 I/O Modules 52mm by 105mm by 60mm

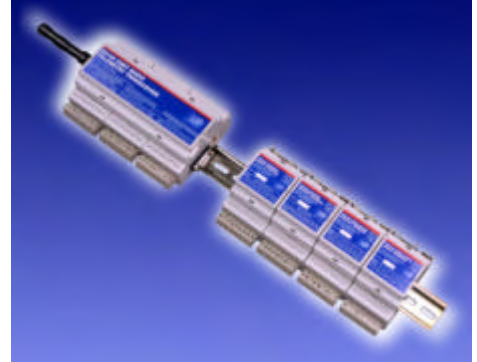

DESCRIPTION

The XNET Radio Data Network offers a cost effective and flexible means of transmitting analogue, digital, and pulse counter data over large areas without the need for cables. A programmable modular approach allows the user to configure the exact combination of IO required for a specific application from standard XNET modules. A system can be as simple as a one-way link or as complex as a multi-drop network.

An XNET Control Module consists of:

- | | |
|--|---------------------------------------|
| 1 Synthesised Radio Transceiver | 1 RS232 Serial Gateway Port |
| 8 Opto Isolated Inputs | 1 RS232 Programming Port |
| 8 Voltage Free Relay Outputs 1A, 30Vdc | 1 X-Bus Expansion Module Port |
| 2 Analogue Inputs ,12bit, 0 to 20mA or 0 to 5V | 1 12V DC Power Supply for Transducers |
| 2 Analogue Outputs, 12 bit, 0 to 20mA or 0 to 5V | |

Additional analogue and digital Input/Output modules can be connected to the Control Module by means of a single 10-way ribbon cable. The modules can be located locally or up to 50 metres away.

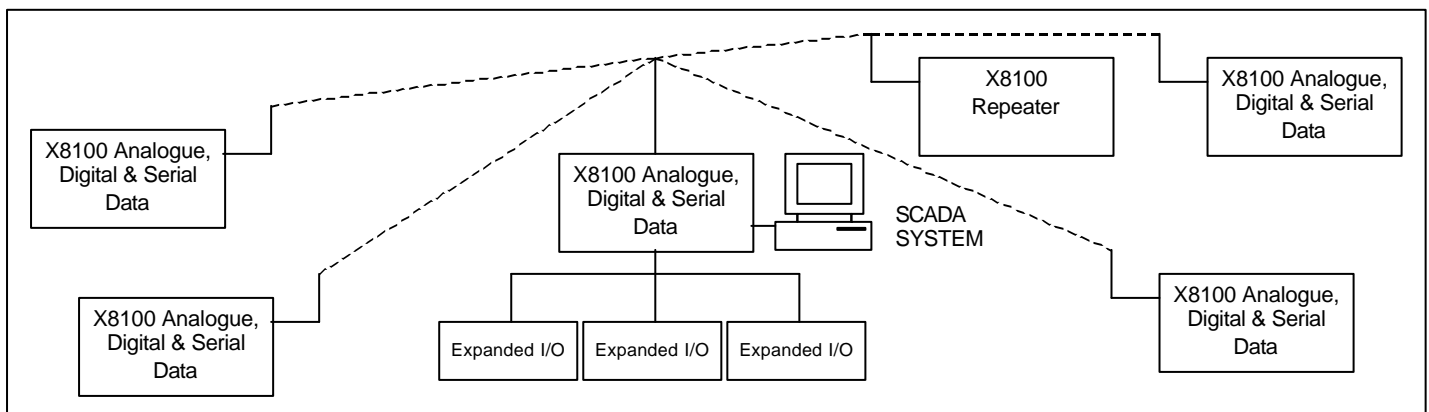

SPECIFICATION

ABSOLUTE MAXIMUM RATINGS

Storage Temperature.....-30 to +85 Celsius
 Operating Temperature.....-10 to +55 Celsius
 Power Supply Voltage +/- 35Vdc
 Digital Inputs+35Vdc to -5V
 Analogue Inputs+35V to -5V
 External Regulated Power Source+100mA

DIMENSIONS

Length = 160mm Width = 80mm Height = 55mm

ELECTRICAL CHARACTERISTICS	MIN	TYPICAL	MAX	DIMENSION	NOTE
Frequency Range	130		180	MHz	VHF
	400		500	MHz	UHF
	860		960	MHz	UHF
Channel Separation	12.5		25.0	KHz	
Modulation		GMSK			
RF Power	5	500	500	mW	
Digital Inputs	7		30	V	
Analogue Inputs	0	20	20	mA	Current I/P
	0	5	10	V	Voltage I/P Thermocouple
Volt Free Contacts			30	Vdc	At 1A
			125	Vac	At 0.5A
Analogue Outputs	0	20	20	mA	12 bit resolution
	0.5	5	10	V	
Power Supply Voltage	14		30	Vdc	DC PSU
	110		240	Vac	AC PSU
Transmit Current	80	90	120	mA	10mW ERP
	410	420	440	mA	500mW ERP
Receiver Current	150	160	180	mA	
Standby Current	2	3	4	mA	

XNET OPERATION

XNET control modules communicate with each other by means of time division multiplexing. All control modules in the network are set by the user to the same RF frequency and then programmed with consecutive node addresses. These are then used as time slots. The control module with time slot zero will start the sequence by transmitting the status of its inputs with the addresses of the destination digital outputs. After receiving data from the first Node a timing pulse will be sent from Node 0 to request data from the next Node. When there is a time break of 6 time slots, the control module with time slot zero will start the sequence again. The network can be easily expanded by adding control modules programmed with the next node address in the sequence.

XNET control modules can be configured as repeaters thereby extending the range of a network over geological obstacles.

CONNECTIONS

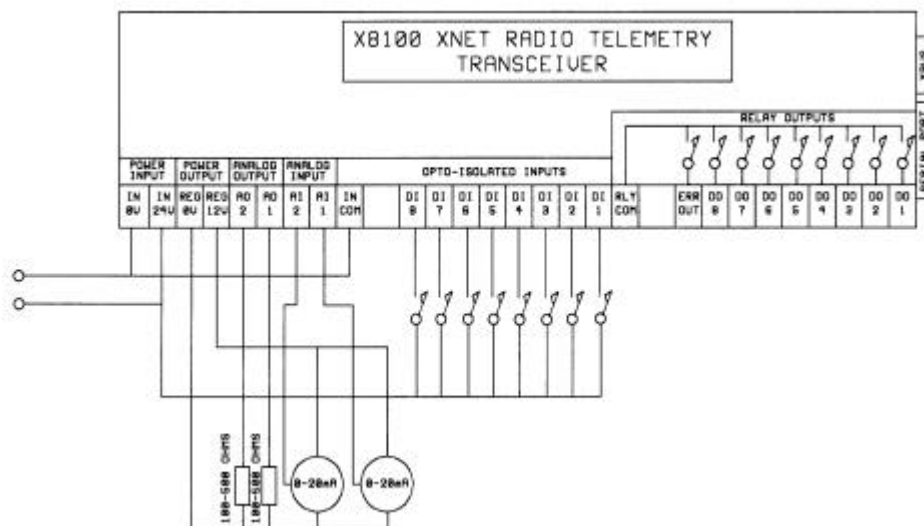

PIN	FUNCTION	DESCRIPTION	DIRECTION
1	0V	Power Supply -Ve	IN
2	24V	Power Supply +Ve	IN
3	REG 0V	Transducer Regulated 0V	OUT
4	REG 12V	Transducer Regulated 12V at 100mA	OUT
5	AO2	Second Analogue Output (0-20mA) OUT 1.2	OUT
6	AO1	First Analogue Output (0-20mA) OUT 1.1	OUT
7	AI2	Second Analogue Input (0-20mA) IN 1.2	IN
8	AI1	First Analogue Input (0-20mA) IN 1.1	IN
9	IN COMM	Opto-Isolated Common (0V)	IN
10	DI8	Opto-Isolated Input (7 - 30V) IN 1.8	IN
11	DI7	Opto-Isolated Input (7 - 30V) IN 1.7	IN
12	DI6	Opto-Isolated Input (7 - 30V) IN 1.6	IN
13	DI5	Opto-Isolated Input (7 - 30V) IN 1.5	IN
14	DI4	Opto-Isolated Input (7 - 30V) IN 1.4	IN
15	DI3	Opto-Isolated Input (7 - 30V) IN 1.3	IN
16	DI2	Opto-Isolated Input (7 - 30V) IN 1.2	IN
17	DI1	Opto-Isolated Input (7 - 30V) IN 1.1	IN
18	RLY COM	Output Relay Common Contact	IN
19	ERR OUT	Communications Fail Indication (1A at 30V)	OUT
20	D08	Relay Output 8 (1A at 30V) OUT 1.8	OUT
21	D07	Relay Output 7 (1A at 30V) OUT 1.7	OUT
22	D06	Relay Output 6 (1A at 30V) OUT 1.6	OUT
23	D05	Relay Output 5 (1A at 30V) OUT 1.5	OUT
24	D04	Relay Output 4 (1A at 30V) OUT 1.4	OUT
25	D03	Relay Output 3 (1A at 30V) OUT 1.3	OUT
26	D02	Relay Output 2 (1A at 30V) OUT 1.2	OUT
27	D01	Relay Output 1 (1A at 30V) OUT 1.1	OUT

PROGRAMMING

An XNET control module is programmed by a PC or Organiser configured as a dumb terminal. A three wire asynchronous RS232 serial port (RD, TD, 0V) with a baud rate set at 9600 with 2 stop bits and no parity is connected to the control module programming port. When the Esc key is pressed, a configuration menu will be displayed. Control Parameter such as node number and serial data port can be selected along with allocating the destination of the node input ports.

RADIO TRANSMISSION

Radio Frequency for the UK Licence Exempt Band

HEX CHANNEL	RF CHANNEL	RF FREQUENCY MHZ	SW5	SW3	SW2	SW1	NOTES
02H	A	458.525	ON	ON	ON	ON	
04H	B	458.550	ON	ON	OFF	OFF	
06H	C	458.575	ON	ON	OFF	ON	
08H	D	458.600	ON	OFF	ON	OFF	
0AH	E	458.625	ON	ON	ON	ON	
0CH	F	458.650	ON	ON	OFF	OFF	
0EH	G	458.675	ON	ON	OFF	ON	
10H	H	458.700	ON	OFF	ON	OFF	
12H	I	458.725	ON	OFF	ON	ON	
14H	J	458.750	ON	OFF	OFF	OFF	
16H	K	458.775	ON	OFF	OFF	ON	
18H	L	458.800	ON	OFF	ON	OFF	
1AH	M	458.825	ON	OFF	ON	ON	NOT USED
1CH	N	458.850	ON	OFF	OFF	OFF	
1EH	O	458.875	ON	OFF	OFF	ON	
20H	P	458.900	ON	OFF	ON	OFF	NOT USED
22H	Q	458.925	OFF	ON	ON	ON	

Note: SW1,SW2,SW3,SW4 and SW5 refer to the DIL switches located inside the RF Module

To change the RF Frequency remove the top plate from the case and set the DIL switches.

INPUT / OUTPUT MODULES

The number of inputs and outputs connected to an X8100 Transceiver can be expanded from 2 Analogue Inputs/Outputs and 8 Digital Inputs/Outputs to 128 Analogue Inputs/Outputs and 128 Digital Inputs/Outputs by means external modules:

- X8101 Digital Input Module with 8 Opto-Isolated Inputs
- X8102 Digital Output Module with 8 voltage free relay contacts rated at 1A , 30Vdc
- X8103 Pulse Counter Output with 8 open collector outputs
- X8104 Analogue Input Module with 4 Analogue Inputs, 12 bit resolution, 0-20mA (standard) 0-5V, 0-10V
- X8105 Analogue Output Module with 4 Analogue Outputs, 12 bit resolution, 0-20mA (standard) 0-5V.

SCADA PACKAGES

A Prodigy SCADA Package running under Windows NT can be connected directly to the serial port providing Mimic Displays, Real Time Monitoring, Alarms and Historic Trending.