

Thank you for your selection of the 405U radio modem. We trust it will give you many years of valuable service.

## ATTENTION!

Incorrect termination of supply wires may cause internal damage and will void warranty.

To ensure your 405U enjoys a long life,

**double check ALL your connections with  
the user's manual**  
before turning the power on.



UK / Europe Office  
Tel: +44 (0)8700 434040  
Fax: +44 (0)8700 434045  
[info@omniinstruments.co.uk](mailto:info@omniinstruments.co.uk)  
[www.omniinstruments.co.uk](http://www.omniinstruments.co.uk)

Australia / Asia Pacific Office  
Tel +61 (0)282 442 363  
Fax +61 (0)294 751 278  
[info@omniinstruments.com.au](mailto:info@omniinstruments.com.au)  
[www.omniinstruments.com.au](http://www.omniinstruments.com.au)

USA / Canada Office  
Tel +1-866-849-3441  
Fax +1-866-628-8055  
[info@omniinstruments.net](mailto:info@omniinstruments.net)  
[www.omniinstruments.net](http://www.omniinstruments.net)

## How to Use This Manual

To receive the maximum benefit from your 405U product, please read the **Introduction**, **Installation** and **Operation** chapters of this manual thoroughly before putting the 405U to work.

Chapter Four **Configuration** details the configurations available and explains the diverse operation of the product in detail.

Chapter Five **Specifications** details the features of the product and lists the standards to which the product is approved.

Chapter Six **Troubleshooting** will help if your system has problems and Chapter Seven specifies the **Warranty and Service** conditions.

The foldout sheet *405U Installation Guide* is an installation drawing appropriate for most applications.

## WARNING

1. In some countries, a radio licence is not required for the 405U telemetry modules provided the module is installed using the antenna and equipment configuration described in the 405U *Installation Guide*. In other countries, refer to the relevant Regulatory Authority. Check the *Installation Guide* for your country listing.
2. Where a radio licence is not required, operation is authorised by the relevant Authority in your country on a non-protection basis. Although all care is taken in the design of these units, there is no responsibility taken for sources of external interference. Some delay in the operation of the module may occur during periods of interference. Systems should be designed to be tolerant of these delays.
3. To avoid the risk of electrocution, the antenna, antenna cable, and all terminals of the 405U module should be electrically protected. To provide maximum surge and lightning protection, the module should be connected to a suitable earth and the antenna, antenna cable, and the module should be installed as recommended in the *Installation Guide*.
4. To avoid accidents during maintenance or adjustment of remotely controlled equipment, all equipment should be first disconnected from the 405U module during these adjustments. Equipment should carry clear markings to indicate remote or automatic operation. eg. "This equipment is remotely controlled and may start without warning. Isolate at the switchboard before attempting adjustments."
5. The 405U module is not suitable for use in explosive environments without additional protection.

---

## CONTENTS

|                      |   |           |
|----------------------|---|-----------|
| <b>CHAPTER ONE</b>   | <b>INTRODUCTION.....</b>                                | <b>7</b>  |
| 1.1                  | GENERAL.....  | 7         |
| 1.2                  | TRANSPARENT MODE.....                                   | 8         |
| 1.3                  | CONTROLLED MODE.....                                    | 9         |
| 1.4                  | REPEATER UNITS.....                                     | 10        |
| <b>CHAPTER TWO</b>   | <b>INSTALLATION.....</b>                                | <b>11</b> |
| 2.1                  | GENERAL.....  | 11        |
| 2.2                  | ANTENNA INSTALLATION.....                               | 11        |
| 2.2.1                | Dipole antenna.....                                     | 12        |
| 2.2.2                | Three element Yagi antenna.....                         | 12        |
| 2.2.3                | Collinear (3dB) antenna.....                            | 13        |
| 2.3                  | POWER SUPPLY.....                                       | 14        |
| 2.4                  | SERIAL CONNECTIONS.....                                 | 14        |
| 2.4.1                | RS232 Serial Port.....                                  | 14        |
| 2.4.2                | RS485 Serial Port.....                                  | 15        |
| 2.5                  | COMMUNICATIONS OK (DCD) OUTPUT.....                     | 16        |
| <b>CHAPTER THREE</b> | <b>OPERATION.....</b>                                   | <b>17</b> |
| 3.1                  | POWER-UP AND NORMAL OPERATION.....                      | 17        |
| 3.2                  | SERIAL AND RADIO DATA.....                              | 18        |
| 3.2.1                | Character Type.....                                     | 18        |
| 3.2.2                | Serial Data Rate.....                                   | 19        |
| 3.2.3                | Radio Data Rate.....                                    | 19        |
| 3.3                  | ADDRESSING.....   | 20        |
| 3.4                  | TRANSPARENT MODE.....                                   | 20        |
| 3.5                  | TRANSPARENT MODE REPEATERS.....                         | 21        |
| 3.6                  | CONTROLLED MODE.....                                    | 23        |
| 3.7                  | WHAT OPERATING MODE TO USE ?.....                       | 27        |
| 3.8                  | OPERATING PROBLEMS.....                                 | 29        |
| <b>CHAPTER FOUR</b>  | <b>CONFIGURATION.....</b>                               | <b>30</b> |
| 4.1                  | BEFORE CONFIGURING.....                                 | 30        |
| 4.2                  | ADDRESSING.....   | 30        |
| 4.3                  | HAYES COMMANDS.....                                     | 31        |
| 4.3.1                | Unit Reset.....   | 31        |
| 4.3.2                | Storing Configuration Parameters - Write Registers..... | 31        |
| 4.3.3                | Default Values - Restore Factory Defaults.....          | 31        |
| 4.3.4                | S-Registers.....  | 31        |
| 4.3.5                | Controlled Mode - autodial.....                         | 36        |

|   |   |           |
|---|---|-----------|
| 4.3.6   | Controlled Mode – single dial .....                           | 36        |
| 4.3.7   | Reading Configuration Parameters .....                        | 37        |
| 4.3.8   | Unit Test commands - AT&Tx .....                              | 37        |
| 4.3.9   | Version Information - ATl.....                                | 37        |
| 4.3.10  | Character Type - AT&Bx.....                                   | 37        |
| 4.3.11  | Character Type - AT&Mx.....                                   | 38        |
| 4.3.12  | Verbose mode control, Local Echo control, and Quiet mode..... | 38        |
| 4.3.13  | Responses .....   | 38        |
| 4.4   | CONFIGURATION EXAMPLES.....                                   | 39        |
| <b>CHAPTER FIVE SPECIFICATIONS .....</b>          |   | <b>42</b> |
| <b>CHAPTER SIX TROUBLESHOOTING.....</b>           |   | <b>44</b> |
| 6.1   | DIAGNOSTICS CHART .....                                       | 44        |
| 6.2   | TEST FUNCTIONS.....   | 44        |
| 6.2.1   | Radio Testing using Tone Reversals.....                       | 44        |
| 6.2.2   | Diagnostic Functions - AT&Tx .....                            | 45        |
| 6.2.3   | Bit Error Rate Test (BER).....                                | 47        |
| <b>CHAPTER SEVEN WARRANTY &amp; SERVICE .....</b> |   | <b>48</b> |
| <b>APPENDIX A SWITCH CONFIGURATION .....</b>      |   | <b>49</b> |
| 1.0   | INTRODUCTION.....   | 49        |
| 1.0.1   | Default Configuration.....                                    | 50        |
| 1.0.2   | Transparent Mode .....  | 50        |
| 1.0.3   | Controlled Mode .....   | 50        |
| 1.1   | CONFIGURATION PARAMETERS .....                                | 55        |
| 1.1.1   | Operating Mode.....   | 56        |
| 1.1.2   | Tail Time.....  | 56        |
| 1.1.3   | Message Length.....   | 56        |
| 1.1.4   | Serial Data Rate.....   | 57        |
| 1.1.5   | Radio Data Rate.....  | 57        |
| 1.1.6   | Transmit Hold-off Time .....                                  | 57        |
| 1.1.7   | Receive Hold-off Time.....                                    | 58        |
| 1.1.8   | Character Type .....  | 58        |
| 1.1.9   | Connect Update Time .....                                     | 59        |
| 1.1.10  | Reset to Factory Default Settings .....                       | 59        |
| 1.2   | CONFIGURATION EXAMPLE.....                                    | 59        |
| <b>APPENDIX B DECIMAL TO BINARY TABLE.....</b>    |   | <b>62</b> |

# Chapter One

# INTRODUCTION

## 1.1

## General

The 405U radio modem module has been designed to provide flexible and reliable radio modem functions, at an economical price. *Radio modems* transmit serial data over a long distance via radio. The serial data is not changed - the output data is the same as the input data. Although the 405U is intended to be simple in its application, it also provides many sophisticated features. This manual should be read carefully to ensure that the modules are configured and installed to give reliable performance.

Each 405U module will connect to a host device by RS232 or RS485 serial connection. Examples of host devices are PLC's, data loggers, intelligent transducers and computers. The 405U unit can receive data from the host device and transmit this data by radio to another (or several) 405U module. The other module will recreate the serial data and output it as either a RS232 or RS485 serial signal. The 405U unit provides two-way communications - each module can accept serial data and also output serial data.

The 405U module includes power supply, microprocessor controller, serial input/output circuits and a UHF radio transceiver - no external electronics are required. The 405U radio frequency has been selected to meet the requirements of unlicensed operation for remote monitoring and control of equipment. That is, a radio licence is not required for the 405U modules in many countries. See Chapter Five **Specifications** for details. The units are configured from a terminal using Hayes commands or by using switches under the plastic cover on the front of the unit.

RS232 is an electrical standard format for a full duplex point-to-point serial connection. RS485 is an electrical standard format for a half-duplex multidrop serial connection. Up to 32 devices can communicate on a common RS485 serial bus. Each 405U unit can only connect to one serial signal - either RS232 or RS485. However different modules in the same system can connect to different types of serial signals. For example, RS232 data from one host device can be transmitted to a remote 405U unit and output as RS485 data to another host device.

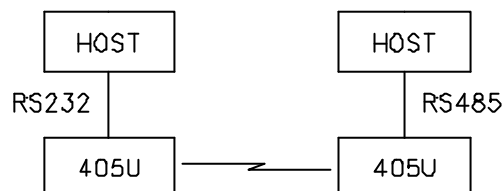

The 405U has been designed to be flexible enough to cover a wide range of applications. The user is able to configure many different parameters such that the 405U unit will connect reliably to different types of host devices. Before the radio modem can be used, these parameters must be configured. Some of these parameters are :-

- Character type - the 405U will accept a variety of 7 or 8 data bit characters
- Serial Data Rate - between 75 and 38400 bits/sec
- Radio Data Rate - between 1200 and 9600 bits/sec
- Operating mode - transparent mode or controlled mode .

The operation of the 405U radio modem is relatively simple. As data is received at the serial port, the data is transmitted on the radio channel. Up to 520 bytes of data can be

transmitted in one transmission. The radio transmission commences when the first data byte is received, and ends when there are no more data bytes in the input buffer, or when the number of bytes transmitted equals the maximum message length (user configurable - default 520 bytes). If more than 520 bytes is input, the 405U unit will transmit the first 520 bytes, then the next 520 bytes, and so on until all of the data has been transmitted.

Because the radio data rate could be less than the input serial data rate, an input memory buffer of 8Kbytes is provided. The RS232 connection provides CTS control to prevent the buffer overflowing. There are no data flow control signals for RS485.

A radio channel cannot provide as secure a data channel as a wired connection. The 405U uses a UHF radio channel with a very low level of natural or industrial noise, however there is a chance of interference from other users of the unlicensed radio channel. We recommend that the flow of data over the radio channel is controlled by using error detection and "handshaking" - that is, returning an acknowledgment transmission if a data packet is received on the radio channel without error. This function can be performed by either the host devices or the 405U modules. The modules may be configured by the user to operate in one of two modes. In transparent mode, it is assumed that the host devices control the flow of data. In controlled mode, the 405U units control the flow of data.

## 1.2

## Transparent Mode

The default configuration of the 405U modem is transparent mode - the modules are set in this mode at the factory. In transparent mode, the 405U provides no control of the data transmissions (no error correction). Input data is simply transmitted by radio and every other 405U unit in that system which receives the transmission will output the data. This mode relies on the host devices to perform the "handshaking" function, and re-transmitting serial data if the data is corrupted (no "handshake"). It also relies on the host devices to include any addressing necessary in the data. In this mode, modules are not configured with a unit address. Data is "broadcast" -

every other 405U in the system will receive the data and output the data to their individual host devices. The user may configure the 405U modems to add error checking to each data packet transmitted - if error checking is configured, data will not be output if it is received without a correct error-check. This feature provides additional protection against corruption of the data during the radio transmission. If error-checking is not configured, then the data received by radio will be output without checking for errors.

Transparent mode is "point-to-multipoint" communications, suitable for a host device which is able to communicate on a multi-drop "bus" type network. An example of an application is the use of radio modems to extend a PLC RS485 network. The serial messages from the PLC's already include PLC addressing and error detection/correction to control the flow of data.

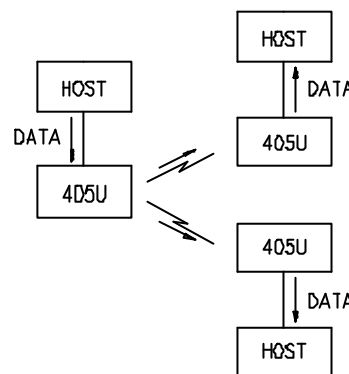

1.3

Controlled Mode

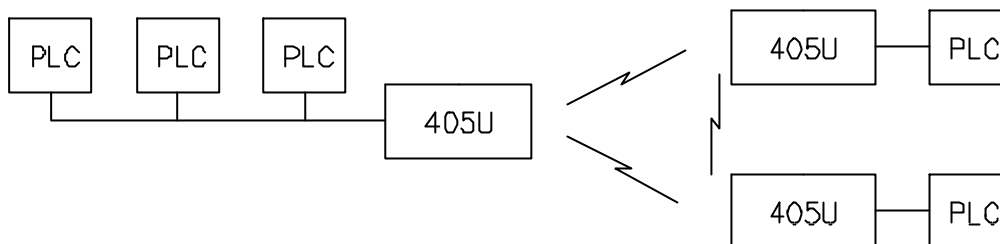

“Controlled mode” provides “point-to-point” communications similar to telephone modems. In controlled mode, the flow of data is controlled by the 405U units. Each 405U unit is configured with an address by the user, and a destination address for the data to be transmitted to. Data is transmitted addressed to the destination module, and only this module will output the serial data. The source module will add an error-check (16 bit CRC) to the data transmitted by radio. The destination module will process the error-check, and if correct, it will transmit an acknowledgment message (ACK) back to the source module. If the error-check is not correct, then the destination module will transmit a “fail” message (NACK) back to the source module. If the source module receives a NACK return, or does not receive any return within 1 second, it will re-transmit the data. The source module will attempt to transmit the data up to five times, until an acknowledgment (ACK) is received. If an acknowledgment is still not received, then a “communications failure” output will be activated, and the source module will not accept any more input data from its host device.

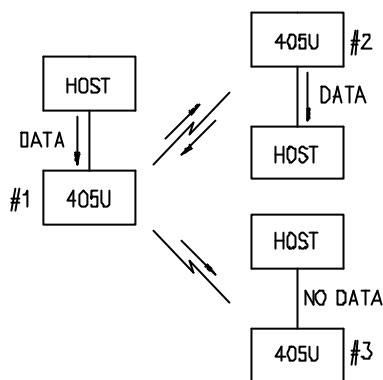

An example of an application using controlled mode would be a radio modem link between an intelligent gas analyser and a monitoring computer system. Intelligent transducers do not normally provide addressing or error checking functions - these would be provided by the 405U modules.

In controlled mode, the destination address may be set by the host device by initially sending a “Hayes” command to the 405U module, or by on-board miniature switches. Hayes commands are a standard set of commands used with conventional telephone modems. An example of an application that would use Hayes command to set destination addresses would be a central computer polling data loggers for periodic information.

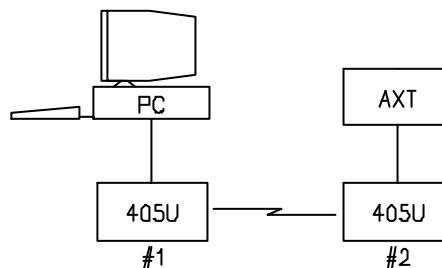

# 1.4

## Repeater Units

A 405U unit may be used as a repeater to re-transmit radio messages. The purpose of a repeater unit is to extend radio range.

In transparent mode, there are two repeater modes. In the normal transparent mode repeater mode, only one module per system may be used as a repeater. If more than one module is configured as a repeater, any message transmitted in the system will be continually re-transmitted between the repeater units.

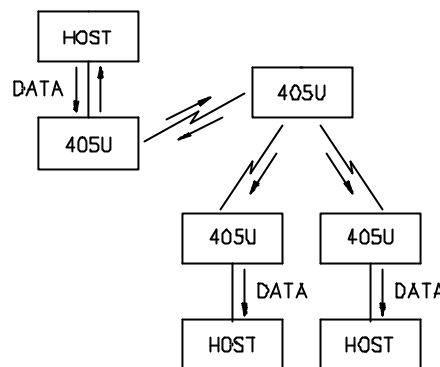

The second transparent repeater mode, called “enhanced transparent repeater”, allows an unlimited number of repeaters, however with some conditions (refer to Section 3.5).

The repeater in transparent mode will repeat every transmission it receives.

In controlled mode, up to five repeaters may be configured for any transmission path. The repeaters are configured by address.

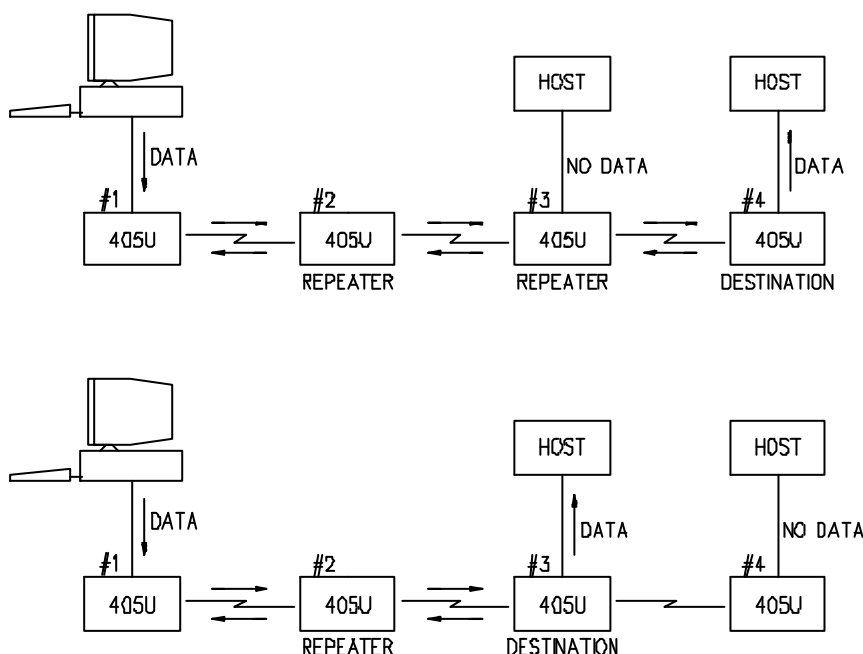

---

# Chapter Two

# INSTALLATION

---

## 2.1

## General

---

The 405U module is housed in a rugged aluminium case, suitable for DIN-rail mounting. Terminals will accept wires up to 2.5 sqmm in size.

**Normal 110-240V mains supply should not be connected to any terminal of the 405U module.** Refer to Section 2.3 **Power Supply**.

Before installing a new system, it is preferable to bench test the complete system. Configuration problems are easier to recognise when the system units are adjacent. Following installation, the most common problem is poor communications caused by incorrectly installed antennas, or radio interference on the same channel, or the radio path being inadequate. If the radio path is a problem (ie path too long, or obstructions in the way), then higher performance antennas or a higher mounting point for the antenna may rectify the problem. Alternately, use an intermediate 405U Module as a repeater.

The foldout sheet 405U *Installation Guide* provides an installation drawing appropriate to most applications. Further information is detailed below.

Each 405U module should be effectively earthed via the "GND" terminal on the 405U module - this is to ensure that the surge protection circuits inside the 405U module are effective.

---

## 2.2

## Antenna Installation

---

The 405U module will operate reliably over large distances. The distance which may be reliably achieved will vary with each application - depending on the type and location of antennas, the degree of radio interference, and obstructions (such as hills or trees) to the radio path. See the 405U *Installation Guide* for expected ranges in your country. Note that the expected range is for radio data rates of up to 4800 bits/sec. If 9600 bit/sec rate is configured, the transmitted data will not have the same range. The radio range for 9600 bit/sec rate will be approx 70% of the range at lower data rates.

Where it is not possible to achieve reliable communications between two 405U modules, then a third 405U module may be used to receive the message and re-transmit it. This module is referred to as a repeater.

An antenna must be connected to each 405U module using the BNC female connector at the top of the module.

To achieve the maximum transmission distance, the antennas should be raised above intermediate obstructions such that the radio path is true "line of sight". Because of the curvature of the earth, the antennas will need to be elevated at least 5 metres above ground for paths greater than 5 km (3 miles). For short distances, the modules will operate reliably with some obstruction of the radio path. Obstructions which are close to either antenna will have more of a blocking effect than obstructions in the middle of the radio path. For example, a group of trees around the antenna is a large obstruction, and the antenna should be raised above the trees. However if there is at least 100 metres of clear path before a group of trees, the trees will have little effect on the radio path.

An antenna should be connected to the module via 50 ohm coaxial cable (eg RG58 or RG213) terminated with a male BNC connector. The higher the antenna is mounted, the greater the transmission range will be, however as the length of coaxial cable increases so do cable losses. For use on unlicensed frequency channels, there are several types of antennas suitable for use. It is important antennas are chosen carefully to avoid contravening the maximum power limit on the unlicensed channel - if in doubt refer to an authorised service provider.

Connections between the antenna and coaxial cable should be carefully taped to prevent ingress of moisture. Moisture ingress in the coaxial cable is a common cause for problems with radio systems, as it greatly increases the radio losses. We recommend that the connection be taped with a layer of PVC insulating tape, then a layer of vulcanising tape such as "3M 23 tape", with a final layer of PVC insulating tape.

Where antennas are mounted on elevated masts, the masts should be effectively earthed to avoid lightning surges. Although the 405U module is fitted with surge protection, additional surge suppression devices are recommended if lightning surge problems are experienced. If the antenna is not already shielded from lightning strike by an adjacent earthed structure, a lightning rod may be installed above the antenna to provide shielding.

### 2.2.1 Dipole antenna.

A unity gain dipole is the normal antenna for use on unlicensed channels. As it does not provide any gain, then the power transmitted from the antenna will be the same as the power out of the module, and hence will not exceed the permitted power of the unlicensed channel.

For marginal radio paths, the following lengths are the recommended **maximum** for the coaxial cable to the dipole antenna. RG58 10 metres RG213 20 metres. Note that this applies to marginal paths only - if the radio path has a strong radio signal, then longer lengths of cable ( and hence more cable loss) can be tolerated. If more than 20 metres of cable is required for a marginal path installation, then a low loss cable such as RG9913 should be used. Alternatively, a higher gain antenna may be used to compensate for losses.

Dipole antennas should be mounted vertically, at least 1 metre away from a wall or mast.

### 2.2.2 Three element Yagi antenna.

A 3 element Yagi antenna provides approx 4 dB of gain. This may be used to compensate for coaxial cable loss for installations with marginal radio path. Note that these antennas should not be used if the coaxial cable lengths are less than the following **minimum** lengths, otherwise the power transmitted from the antenna will exceed the power permitted for the unlicensed channel.

|       |            |
|-------|------------|
| RG58  | 10 metres  |
| RG213 | 20 metres. |

Yagi antennas are directional. That is, they have positive gain to the front of the antenna, but negative gain in other directions. Hence Yagi antennas should be installed with the central beam horizontal and must be pointed exactly in the direction of transmission to benefit from the gain of the antenna. Also note that Yagi antennas normally have a drain hole on the folded element - the drain hole should be located on the bottom of the installed antenna.

The Yagi antennas may be installed with the elements in a vertical plane (vertically polarised) or in a horizontal plane (horizontally polarised). For a two station installation, with both modules using Yagi antennas, horizontal polarisation is recommended. If there are more

than two stations transmitting to a common station, then the Yagi antennas should have vertical polarisation, and the common (or “central”) station should have a dipole or collinear antenna.

Yagi antennas should not be used where a module is receiving messages from more than one other module such as repeater or “base-station” situations. An omni-directional antennas such as a dipole or a collinear antenna should be used.

**2.2.3 Collinear (3dB) antenna.**

A 3dB collinear antenna may be used in the same way as a 3 element Yagi to compensate for the losses in long lengths of coaxial cable. This type of antenna is generally used at a central site with more than one remote site. The collinear antenna looks similar to the dipole, except that it is longer.

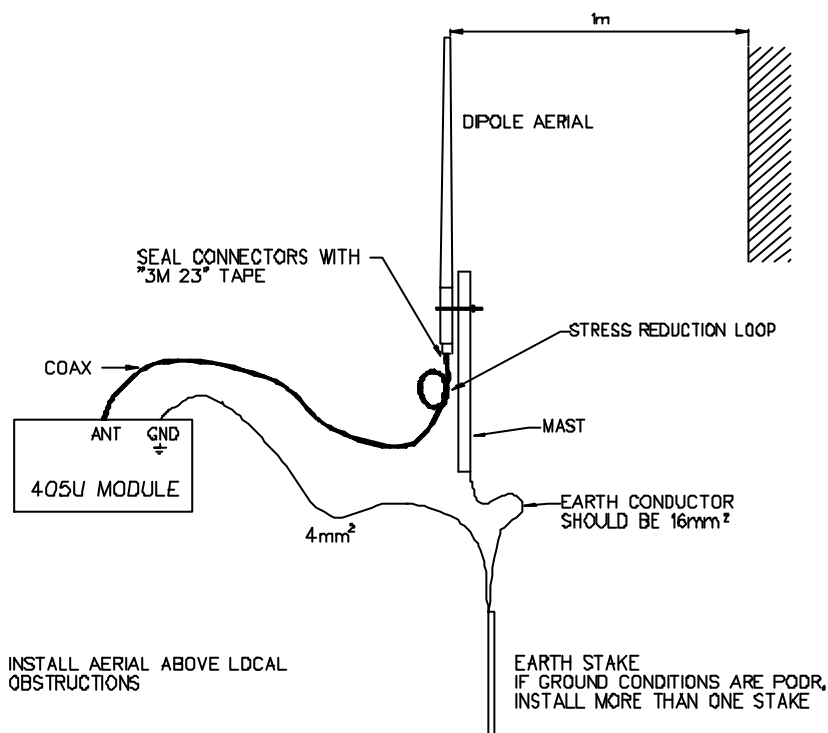

## 2.3

## Power Supply

The 405U module may be powered by either a 12VDC or a 24VDC supply.

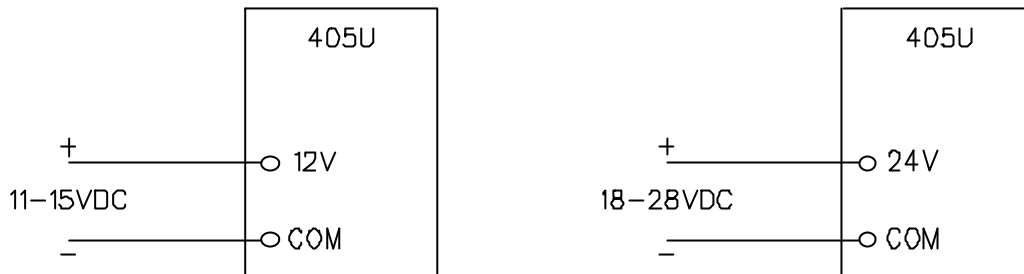

The negative side of the supply is connected to "COM" and may be connected to "ground". The supply negative is connected to the "GND" terminal internally. The positive side of the supply **must not be connected to earth**. The DC supply may be a floating supply or negatively grounded.

The 12V supply is suitable for an unregulated DC supply. Where battery backup is required, a 12V battery charger may be used to supply the 405U module as well as charging the battery.

The power requirements of the 405U units is 150mA at 12VDC or 120mA at 24VDC. The supply is protected by an internal 500mA fuse, accessible at the bottom of the unit.

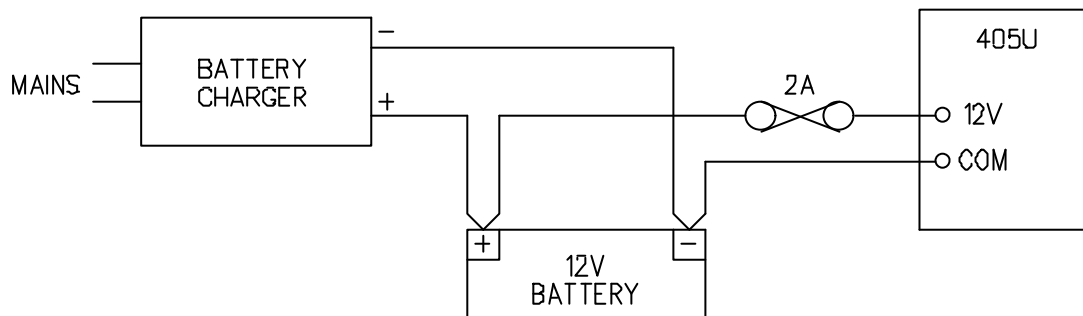

## 2.4

## Serial Connections

### 2.4.1 RS232 Serial Port

The serial port is a 9 pin DB9 female and provides for connection to a host device as well as a PC terminal for configuration, field testing and for factory testing. This port is internally shared with the RS485 - ensure that the RS485 is disconnected before attempting to use the RS232 port. Communication is via standard RS232 signals. The 405U is configured as DCE equipment with the pinout detailed below.

**DB9 Connector Pinout**

| Pin | Name | Direction | Function  |
|-----|------|-----------|---|
| 1   | DCD  | Out       | <b>Data carrier detect</b> - not connected Rev. 1.03 software & earlier<br>Rev. 1.04 & later - driven when link is established in controlled mode<br>- driven always in transparent mode  |
| 2   | RD   | Out       | <b>Transmit Data</b> - Serial Data Output   |
| 3   | TD   | In        | <b>Receive Data</b> - Serial Data Input   |
| 4   | DTR  | In        | <b>Data Terminal Ready</b> - not connected Rev 1.03 & earlier,<br>Rev. 1.04 & later: When in controlled mode, will autodial if destination address is configured In control mode, an inactive DTR will force the 405U to low-power mode.<br>Rev. 1.11 & later: When in controlled mode, will autodial if destination address is configured In control mode, an inactive DTR will force the 405U stop communicating by radio. If low power mode is selected, an inactive DTR will also force the 405U to low power mode. |
| 5   | SG   |           | <b>Signal Ground</b>  |
| 6   | DSR  | Out       | <b>Data Set Ready</b> - always high when unit is powered on.  |
| 7   | RTS  | In        | <b>Request to Send</b> - hardware flow control  |
| 8   | CTS  | Out       | <b>Clear to send</b> - hardware flow control  |
| 9   | RI   |           | <b>Ring indicator</b> - not used or connected   |

Hardware handshaking using the CTS/RTS lines is provided. The CTS/RTS lines may be used to reflect the status of the local unit's input buffer, or may be configured to reflect the status of CTS/RTS lines at the remote site. The 405U does not support XON/XOFF.

Example cable drawings for connection to a DTE host (a PC) or another DCE host (or modem) are detailed below. These example are for transparent mode. Controlled mode may require the use of DTR or DCD signals.

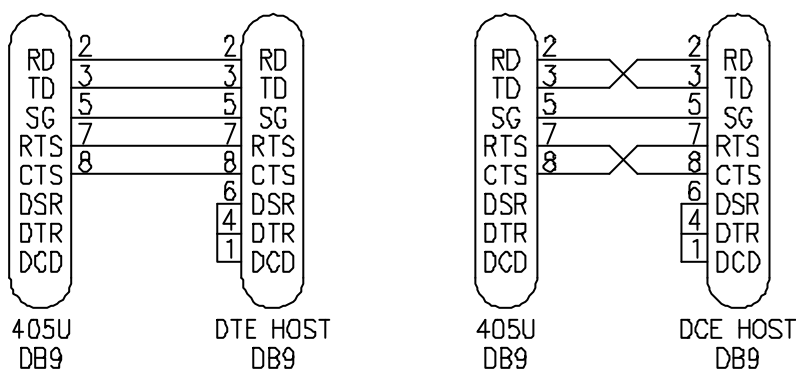

**2.4.2 RS485 Serial Port**

The RS485 port provides for communication between the 405U unit and its host device using a multi-drop cable. Up to 32 devices may be connected in each multi-drop network. Note that the RS485 port is shared internally with the RS232 port - make sure that the RS232 port is disconnected before using the RS485 port.

As the RS485 communication medium is shared, only one of the units in the system may send data at any one time. Thus communication protocols based on the RS-485 standard require some type of arbitration. The 405U “holds off” for three character times after receiving data from the RS-485 port before transmitting on the RS-485 port.

RS485 is a balanced, differential standard but it is recommended that shielded, twisted pair cable be used to interconnect modules to reduce potential RFI. An RS485 network should be wired as indicated in the diagram below and terminated at each end of the network with a 120 ohm resistor. It is important to maintain the polarity of the two RS485 wires.

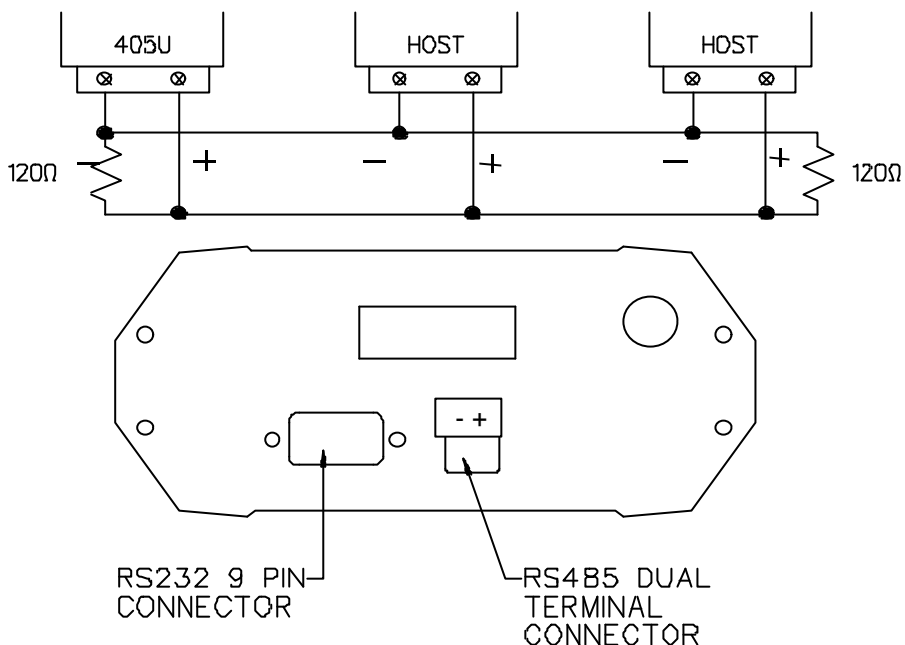

## 2.5 Communications OK (DCD) Output

The 405U provides a digital output signal to indicate “communications OK” in controlled mode. The DCD (data carrier detect) output is “on” or active when a radio link has been established with the destination module. The output will reset (switch “off”) if a communications failure occurs. If the 405U unit does not receive an acknowledgment message after attempting to transmit a data packet five times, it will reset the DCD output.

The output is a FET output to common, rated at 30VDC 500 mA.

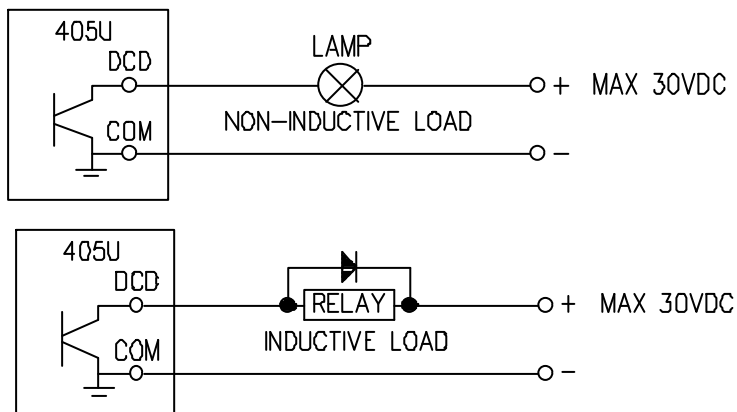

# Chapter Three

# OPERATION

## 3.1 Power-up and Normal Operation

When power is initially connected to the 405U module, the module will perform internal diagnostics to check its functions. The following table details the status of the indicating LEDs on the front panel under **normal** operating conditions.

| LED Indicator | Condition                                      | Meaning   |
|---------------|--|---|
| OK            | On   | Normal Operation  |
| Radio RX      | GREEN flash<br>RED flash                       | Radio receiving data<br>Weak radio signal   |
| Radio TX      | Flash  | Radio Transmitting  |
| Serial RX     | GREEN flash<br>RED flash<br>GREEN continuously | Serial Port Receiving<br>CTS low<br>Configuration Mode  |
| Serial TX     | GREEN flash                                    | Serial Port Transmitting  |
| DCD           | On   | Transparent mode - always on<br>Controlled mode - on when<br>communications link is established |
| DCD           | Off  | Communications failure or link not<br>established   |

Other conditions indicating a fault are described in Chapter Six **Troubleshooting**.

### Low Power Operation

For special installations, the 405U may be operated in a low power condition where it switches off its receiver - power consumption is reduced to approximately 65% of normal. The low power condition will occur if the 405U is configured for controlled mode (modes 2, 3, 6 or 7), AND if an autodial address is configured, AND if the low power mode feature is configured in the "character type" selection, (refer S9 Values) AND if the DTR signal is "low" or "off".

The use of this low power operation may be applicable in remote locations where there is a limited power supply such as solar panels. In this situation, the DTR signal from the host device is used to "wake-up" the 405U unit. The 405U unit will then operate normally until the DTR signal is reset by the host device.

## 3.2

## Serial and Radio Data

Data input at the serial port is placed into the input buffer. This buffer will store 8Kbytes of data, and CTS control is provided on the RS232 port to prevent overflow.

When the 405U unit detects data in the input buffer, it initiates a radio message. The radio message will end when the number of transmitted bytes reaches the maximum message length (configurable by the user). The message will also end if the input buffer becomes empty, however the radio transmitter will remain active for a delay time in case more bytes are input at the serial port. The delay time is called the "tail time" and is configurable by the user.

If error checking is not configured (modes 0, 2, 4 and 6), then data is transmitted as soon as data is detected in the input buffer - data "streams" from the input buffer to the radio port. The radio transmission will stop when the input buffer is empty (plus the delay time) or when the radio has transmitted the maximum number of bytes (user configurable - maximum 520 bytes). If there is still data in the input buffer, the 405U will start another radio transmission.

If error checking is configured (modes 1, 3, 5 and 7), then data is not transmitted on the radio until a data packet is collected in the input buffer. A 16 bit CRC error-check is then added to the data packet and the data packet transmitted. The maximum size of the data packet is configurable by the user (maximum is 520 bytes). If less data than the maximum size is input to the 405U, then the 405U will transmit the actual data input. If more data is input than the maximum size, then the 405U will transmit multiple packets until all of the data is transmitted.

### 3.2.1 Character Type

The 405U may be configured by the user to recognise the following types of characters.

| Data Bits | Start Bits | Stop Bits | Parity |
|-----------|------------|-----------|--------|
| 7         | 1          | 1         | even   |
| 7         | 1          | 1         | odd    |
| 7         | 1          | 2         | none   |
| 7         | 1          | 2         | even   |
| 7         | 1          | 2         | odd    |
| 8         | 1          | 1         | none   |
| 8         | 1          | 1         | odd    |
| 8         | 1          | 1         | even   |
| 8         | 1          | 2         | none   |

Most applications will require the character type to be the same at each 405U modem in the system. Nevertheless, the character type may be configured to be different at different 405U

modems. Data is transmitted by radio as an eight-bit byte without stop or start bits. If the input data is 7 data bits without parity, then the byte transmitted by radio comprises the 7 bits plus a zero bit. If the input data is 7 data bits with parity, then the byte transmitted comprises the same byte. Input characters with 8 bits are transmitted as just the 8 data bits, with no parity. Because the data may be transmitted without parity, the user may configure CRC error checking to be added to each transmitted data packet. Data is output at the destination module based on the character type configured at that module - that is, the start/stop bits and parity is added to the radio data.

### 3.2.2 Serial Data Rate

The communications baud rates supported on both the RS232 serial port and the RS485 serial port are 50, 75, 150, 300, 600, 1200, 2400, 4800, 9600, 19200, and 38400 baud - the user selects one of these rates during the configuration of the modem.

### 3.2.3 Radio Data Rate

The data is transmitted by radio as direct modulated synchronous data at a rate between 1200 and 9600 bits per second. The user must configure the radio data rate at each 405U module. The configured radio data rates must be the same for each module in a system. The 405U operates on a 12.5KHz radio channel. At 9600 bits/sec, a 405U unit cannot achieve the same reliable radio range as at 4800 bits/sec or less. The range at 9600 bits/sec is approx 70% of the normal range. On noisy radio channels, the range at 9600 baud will be less than 70% - as the noise level increases, the range difference between 4800 baud and 9600 baud increases.

The radio message also includes the following :-

- A 40 msec leading sequence of alternating 1's and 0's provides the receiving unit with time to capture and lock onto the incoming signal.
- A system address is superimposed on each message to provide discrimination between different 405U systems on the same radio channel. Each 405U unit in the same system must be configured with the same system address - refer Section 4, **Configuration**. Although other 405U modules will hear the radio transmissions, because they have a different system address, the radio transmission is ignored and no serial data is output.
- A "frame flag" appears once at the beginning of each message, and once at the end of each message. It indicates the start and end of a message packet.
- An "idle flag" may be used to allow the message to idle for a short period after each character is sent. This allows the 405U unit to effectively transfer data when the data rate arriving at the serial port is lower than the radio data transfer rate. After each character is sent, the transmission remains active waiting for the next character. This is controlled by the "tail time". The tail time may be configured for between 0 and 2.55 seconds - refer Section 4, **Configuration**.
- The RTS status of the source unit is included in the message. In controlled mode only, this is used to set the CTS signal at the destination module.
- In controlled mode, unit addressing is included.
- An error-check (16 bit CRC) may be configured by the user.

Up to 520 bytes of data may be transmitted in a message - the maximum message size is configurable between 10 and 520 bytes. The data consists of a sequence of 8 bit bytes.

Start, stop and parity bits are not transmitted, but they are re-generated at the receiving unit (if configured).

A "transmit delay" time and a "receive delay" time may also be configured. After each message is transmitted, a 405U unit will not transmit another message during the transmit delay time. After a message is received, a message will not be transmitted during the receive delay time. These parameters may be used to fine tune and give priority to different 405U units in a system.

The default time of the transmit delay (70 msec) is selected for polling applications. If the host device sends more than one poll command, the second poll message will be delayed to allow a response to be received for the first poll message. The user can reduce this transmit delay time if it is not required.

## Addressing

A 405U network comprises modules with the same "system" address. This address is configured by the user as part of the module configuration. Only modules with the same system address will communicate with each other. This feature allows more than one system to operate in the same area on the same radio channel.

A 405U can also be configured with a "unit" address - this gives the module a unique identification. The unit address feature is not used in transparent mode, but it is used in controlled mode.

### 3.4

## Transparent Mode

In transparent mode, radio messages are transmitted without unit addressing. Units do not provide handshaking functions to control the flow of data. Every unit which receives the radio message, and has the correct system address, will output the data. Transparent mode operation is effectively a broadcast system.

Data received at the serial port is transmitted out of the radio port. Data received from the radio is transmitted out of the serial port. Prior to transmitting, units will listen to the radio channel to ensure that it is clear - units will hold off from transmitting until the radio channel is clear. At the RS232 port, the CTS pin is high while there is space in the input data buffer.

Host devices should provide a suitable protocol to ensure that error checking, handshaking and implementation of an appropriate re-transmission scheme is provided. This mode of operation is particularly suited to devices designed to operate over a multidrop network, such as PLC systems designed for operation over a RS-485 network.

The time taken to transmit a message is :-

| lead-in system addr | data        | error check (if configured) |             |
|---------------------|-------------|-----------------------------|-------------|
| -----               | -----       | -----                       | -----       |
| 40msec              | 2 bytes     | 1.9ms per byte              | 2 bytes     |
|                     | 4ms @ 4.8KB | @ 4.8KB                     | 4ms @ 4.8KB |

If error checking is not configured at the receiving unit, data will start to be output approximately 1 msec after the system address has been received. If error checking is configured, data will be output approx 2msec after the end of the message. For example, a

---

message with 20 bytes of data transmitted at 4800 bits/sec will be output approx 45msec after the data is input, if there is no error checking, or 82msec after the data is input if error checking is configured.

The time between transmissions is set by the transmit and receive hold-off times configured by the user.

## 3.5 Transparent Mode Repeaters

---

### Simple Repeater

There are two types of transparent mode repeaters. The first is a simple repeater which repeats every message it receives, provided the system address is correct. This repeater is configured as mode 8 in configuration register 0 (refer to section 4.3).

There can only be one simple transparent repeater in each system. If there is more than one repeater, then messages will be transmitted between the repeaters continuously. The repeater module will not output any serial data, so this module is only used as a repeater - it does not connect to a host device.

There are some problems with this mode :

1. Some systems need more than one repeater.
2. When the repeater re-transmits the message, the original source module will hear the re-transmitted message and output it to its host device. Some host devices cannot accept the same message coming back (that is, they cannot accept a message reflection).
3. If a remote 405U can hear the message transmitted from the original source module, then it will hear the message twice - the original message and the re-transmitted message. Its host device will be sent the message twice. Some host devices cannot accept the same message twice.

To get around these problems, there is an enhanced transparent repeater mode

### Enhanced Repeater

An enhanced repeater is configured as mode 9 in configuration register 0 (refer to section 4.3).

The enhanced repeater will receive messages on one system address, and re-transmit the messages on a different system address. The enhanced repeater will take up two system addresses. The first system address will be the address configured in S-registers 6 and 7. The second system address will have a value of 1 more than the first address. For example, if an enhanced repeater is configured with system address 1483, it will operate on system addresses 1483 and 1484.

If an enhanced repeater receives a message on its first system address, it will re-transmit the message on its second system address. That is, the re-transmitted message will now have the second system address. Only 405U modules configured with the second system address will accept the re-transmitted message.

If an enhanced repeater receives a message on its second system address, it will re-transmit the message on its first system address. That is, the re-transmitted message will now have the first system address.

Here is an example :

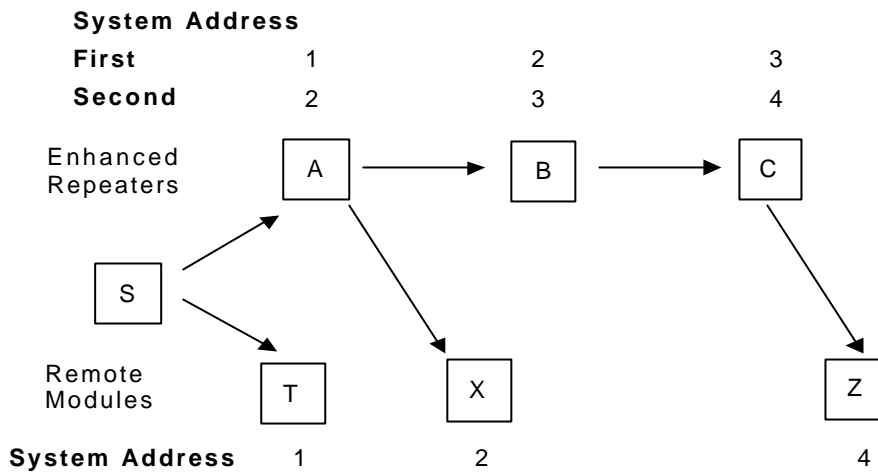

Module A, B and C are configured as enhanced transparent repeaters (mode 9). Module A is configured with system address 1, module B with system address 2 and module C with system address 3. Note that the unit address is not used - this is only used in controlled mode.

Module S and T are configured with system address 1. When S transmits a message, T will receive it and output the data. If module X can hear the message, it will not output it as module X is configured with system address 2.

Repeater A will also receive the message from S, and will re-transmit it, but on system address 2. Module S and T will receive the re-transmitted message, but will not output the message as the system address is now wrong. Module X will receive the message and will output the message as the system address is now correct.

Repeater B will also receive the re-transmitted message from A, and will re-transmit again on system address 3.

The only other module which is also on system address 3 is repeater C. It will accept the message and re-transmit it on system address 4 - to module Z.

Note that when a message is transmitted from a remote module, the repeaters will only transmit a message in one direction. For example :

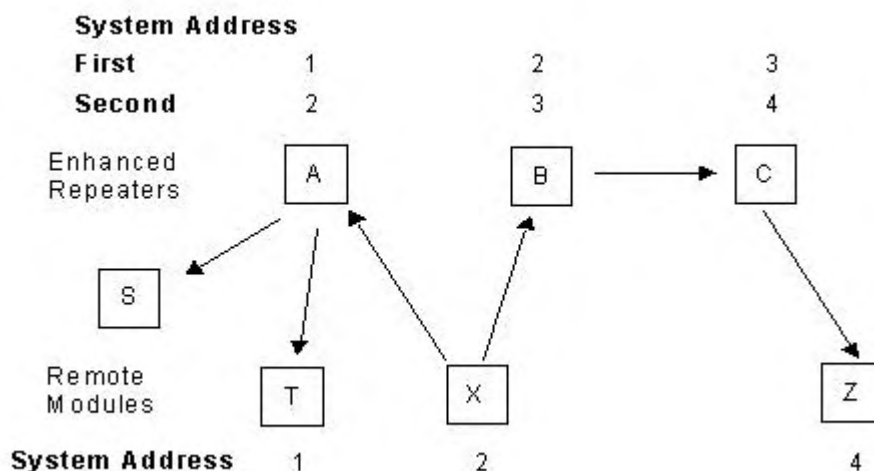

---

When X transmits a message, repeater A will receive the message on system address 2 and re-transmit on system address 1 to modules S and T. But repeater B will not accept the re-transmitted message on system address 1.

If repeater B is able to hear the original message from module X (on system address 2), then it will re-transmit it on. But if it cannot, then the message will not be transmitted on to module Z.

The repeater module will not output any serial data, so repeater module is only used as a repeater - it does not connect to a host device.

### Special Note

Simple repeaters will operate with or without error-checking configured (modes 0, 1, 4 or 5 in configuration register 0). However, enhanced repeaters will only operate without error checking (only modes 0 or 4 in register 0). If you configure error-checking, the error-check will be incorrect at the destination modules and no data will be output.

## 3.6

## Controlled Mode

---

In controlled mode, data is only transferred between two modules (that is, a point to point link). One of the modules is configured as a "master" unit and the other as a "slave" unit. There can also be up to five intermediate repeaters in the link. Each 405U unit is configured with a unit address - only the unit with an address matching the destination address of the radio message will process the message and output the serial data.

To establish a link, the master will transmit a special "connect" message. This initial message will not include any data. If the "slave" unit receives the initial message, and is not already connected to another 405U unit, it will return an acknowledgment message. Both units will activate their DCD LED, and also activate their DCD output signal. If the master unit does not receive the acknowledgment, the DCD output will reset. When the connection is made (DCD set), the 405U units can transmit data to each other.

The destination address may be configured two ways. The AT&Z command (see Section 4, Configuration) enters an "auto-dial" address. The ATD command enters a "single-dial" address. The AT&Z command only has to be entered once, and the 405U remembers the destination address. The ATD command has to be used each time a connection is to be made - the 405U will not remember the previous destination address. If an auto-dial address is configured, the master will transmit the "connect" message every ten seconds until it receives an acknowledgment. If a single-dial address is configured, the master unit will try to connect five times - if no acknowledgment is received, a "BUSY" or "NO ANSWER" response is sent to the host connected to the master. The host must then issue the ATD dial command to the 405U before it will try to connect again.

The auto-dial operation is similar to a fixed line modem, where the destination address is always the same. Once the auto-dial address is configured, it does not need to be entered again. If the communications link fails (DCD resets), the master unit will automatically send connect messages to re-establish the link.

The single-dial operation is similar to a dial-up modem. The 405U will make a connection to another unit only when it is told to by the host device. If the communications link fails for any reason, the master unit will not send a connect message until it receives another ATD command.

Either of the two modules at the end of the link can be the "master" unit - the "master" unit has the responsibility of establishing the radio link and periodically checking the link. Data

can be transferred in both directions - from the "master" to the "slave" and from the "slave" to the "master".

Once the communications channel has been established, the 405U unit will accept input data and send radio messages with data. On the RS232 port, if CTS/RTS is enabled, the CTS signal will be active when the input data buffer is not full, AND the RTS signal at the destination module is active. The local CTS/RTS status will reflect the remote CTS/RTS status, as well as the local input buffer. Note that CTS/RTS is disabled in the default configuration - if this feature is required, it must be enabled (refer Configuration Chapter 4). If CTS/RTS is not enabled, then data will be lost after the input buffer (8KB) is full.

When a 405U unit receives a radio message, it will check the system address and destination address, and also the error-check (optional). If these are correct, it will return a ACK (acknowledgment) message to the source unit. If the system address or destination address is not correct, then no return message is sent. If the addresses are correct, but the error-check incorrect, then a NACK (error) message is sent to the source unit.

If the source unit receives a NACK message, or does not receive any message within 1 second, it will re-transmit the same message. It will attempt to transmit the message up to five times, with a 5 second delay between attempts. If the unit still does not receive an ACK message after five attempts, it will reset the DCD LED, and reset the DCD output. The unsuccessful message will be held in the input buffer until the communications link is re-established. If the source module is the "master" unit, then it will immediately send "connect" messages every ten seconds to the "slave" unit. If the source module was the "slave" unit, then it will wait until it receives a "connect" message from the "master" and the communications channel is re-established.

During normal operation, if there has been no radio activity for a period (called the "update" period), the "master" unit will transmit the "connect" message to check the radio path. The update period is a time configured by the user.

**Establishing a Communications Link**

| Master Unit   | Slave Unit  |
|---|---|
| <ul style="list-style-type: none"> <li>• Listen to ensure channel is clear</li> <li>• If clear, transmit "connect" message -----&gt;</li> <li>• Radio TX LED flashes</li> </ul> | <ul style="list-style-type: none"> <li>• Receives message</li> <li>• Radio RX LED flashes</li> <li>• Check system and destination address</li> <li>• If OK, set DCD LED and output</li> </ul> |
| <ul style="list-style-type: none"> <li>• Radio RX LED flashes &lt;-----</li> </ul>  | <ul style="list-style-type: none"> <li>• If message OK, transmit back an ACK message.</li> <li>• Radio TX LED flashes</li> </ul>  |
| <ul style="list-style-type: none"> <li>• Acknowledgment received okay communication link established</li> <li>• Set DCD LED and output</li> </ul>                               |   |

**Successful Communications**

| Source Module   | Destination Module  |
|---|---|
| <ul style="list-style-type: none"> <li>• Serial data is received</li> <li>• Serial RX LED flashes</li> </ul>  |   |
| <ul style="list-style-type: none"> <li>• Listen to ensure channel is clear</li> <li>• If clear, transmit message</li> <li>• Radio TX LED flashes -----&gt;</li> </ul> | <ul style="list-style-type: none"> <li>• Receive message</li> <li>• Radio RX LED flashes</li> <li>• Check system and destination address</li> <li>• If OK, check error-check</li> </ul> |
| <ul style="list-style-type: none"> <li>• Radio RX LED flashes &lt;-----</li> </ul>  | <ul style="list-style-type: none"> <li>• If message okay, transmit back an ACK message.</li> <li>• Radio TX LED flashes</li> </ul>  |
| <ul style="list-style-type: none"> <li>• Acknowledgment received okay - communication complete</li> </ul>   | <ul style="list-style-type: none"> <li>• Serial data is output</li> <li>• Serial TX LED flashes</li> </ul>  |

**Unsuccessful Communications**

| Source Module   | -----> | Destination Module  |
|---|--------|---|
| <ul style="list-style-type: none"> <li>Listen to ensure channel is clear</li> <li>If clear, transmit message</li> <li>TX LED flashes</li> </ul>                               | -----> | <ul style="list-style-type: none"> <li>Receives message</li> <li>RX LED flashes</li> <li>Check system and destination address</li> <li>If incorrect, transmit no message and no serial output.</li> </ul> |
| <ul style="list-style-type: none"> <li>Radio RX LED flashes</li> </ul>  | <----- | <ul style="list-style-type: none"> <li>If addresses are correct, check error-check.</li> <li>If incorrect, transmit a NACK message</li> <li>TX LED flashes</li> </ul>                                     |
| <ul style="list-style-type: none"> <li>NACK message or no message received</li> <li>Retry up to four times</li> </ul>   | -----> |   |
| <ul style="list-style-type: none"> <li>If no ACK message received after five attempts</li> <li>"Comms fail" output activated</li> <li>DCD signal and DCD LED reset</li> </ul> |        |   |

The time taken to transmit a message is :-

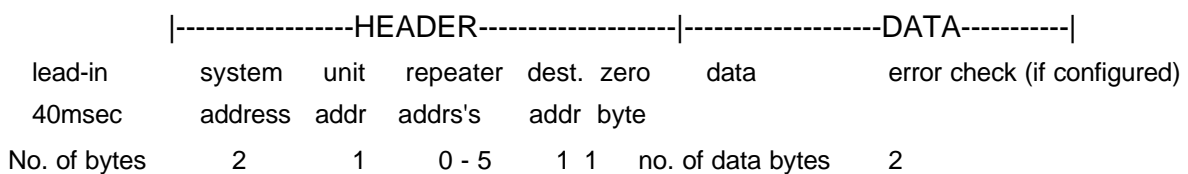

The time for each HEADER byte is 3.8mSec @4800 bits/sec, and the time for each DATA byte is 1.9msec @ 4800 bits/sec.

If error checking is not configured at the receiving unit, data will start to be output approx 1msec after the "zero" byte has been received. If error checking is configured, data will be output approx 2msec after the end of the message. For example, a message with 20 bytes of data transmitted at 4800 bits/sec with no repeaters, will be output approx 88msec after the data is input, assuming that error checking is configured.

The time between transmissions is set by the transmit and receive hold-off times configured by the user.

### Intermediate Repeaters

Where intermediate repeaters are configured, each repeater will re-transmit the message onto the next address. When the destination address is reached, the destination module will return an acknowledgment (ACK) with the reverse address structure as the received message.

If error-checking is selected, then the destination module will only return a ACK if the error check is valid. If the error check is not valid, then a NACK message is returned. If the error-checking function is not selected, then the destination module will return an ACK every time it receives a message (a NACK is never sent). Each repeater will re-transmit the ACK or NACK message until it is received by the source module.

The source module will calculate a waiting time for the acknowledgment - this time is based on the radio baud rate, the message length (number of bytes) and the number of repeaters. If the source module receives a NACK, or it does not receive an ACK within the waiting time, it will transmit the same message again. The 405U will transmit the message up to five times. If it does not receive an ACK after the 5<sup>th</sup> attempt, it will assume communications failure and reset its DCD status. The unsuccessful message will not be re-transmitted and will be lost.

### Repeater Communications *Successful*

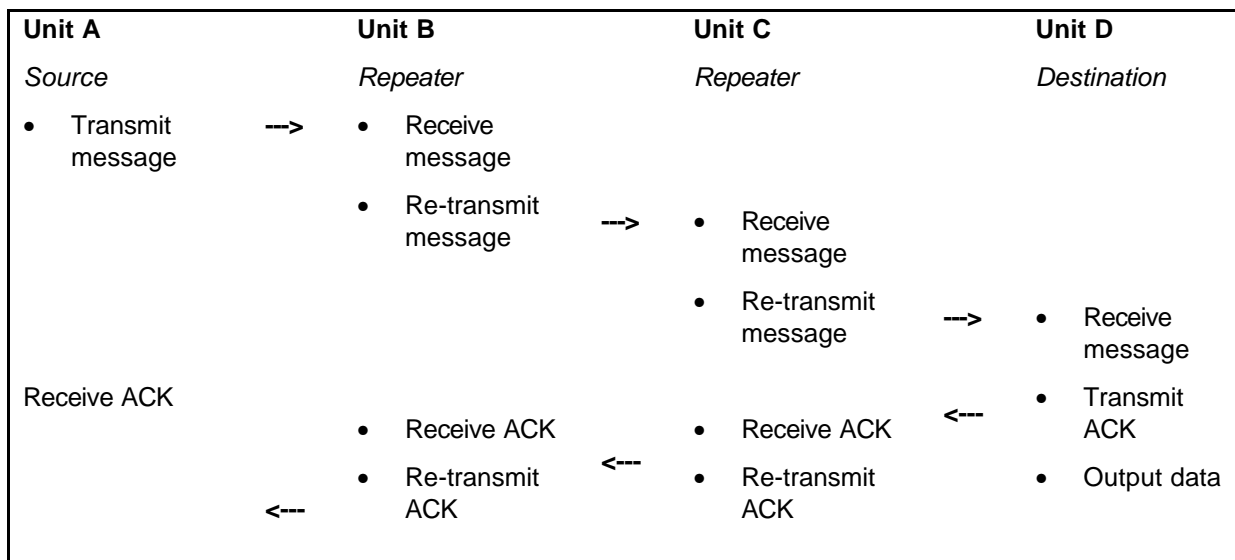

Repeater units may also act as destination addresses for some transmissions and output data to a host device.

## 3.7 What Operating Mode to Use ?

### Transparent or Controlled Mode?

Transparent mode provides faster operation as the units do not acknowledge transmissions received. However reliable operation in transparent mode will only occur if the host devices check the messages and return acknowledgments. Generally, if a device is able to operate on a RS485 multi-drop serial link, it is suitable for transparent mode.

Controlled mode is suitable for point-to-point links, rather than multi-point networks.

If it is not known whether a device is suitable for transparent mode, then controlled mode should be used. If faster operation is desired, then transparent mode can be tried, and if the system operates reliably, then transparent mode is suitable.

It is possible to configure different units in the same system with different operating modes, however the system will not operate. A 405U unit configured in one mode will not process a message received from a unit in the alternate mode.

### **Error Check ?**

Error-checking may be configured in both transparent and controlled mode. When the error-check is configured, two additional bytes are attached to the end of each message. These bytes are used to detect any corruption of the data when it is received at another 405U unit.

When a unit with error-check configured receives a radio message, it will not output data until it has received the whole message and ensures that the error-check is correct. If the unit does not have error-check configured, then it will output data as it is received. Hence operation of the units is faster if error-check is not configured.

We recommend that units in the same system have the same error-check configuration, however it is possible for users to configure the units differently. If a unit without error-check configured receives a message which includes an error-check, then the unit will treat the additional two bytes as data and output them to the host device. If a unit with error-check configured, receives a message without an error-check, it will treat the last two data bytes as the error check - the error-check will always be incorrect and no data will be output.

Error-check is strongly recommended for controlled mode operation. If error-check is not configured, then a 405U unit will transmit an acknowledgment message (ACK) whenever it receives a radio message, without checking for errors. If error-check is configured, the unit will only transmit an ACK message if the error-check is correct. If it is incorrect, an error message (NACK) is returned to the source address.

### **Autoconnect or Host-connect modes?**

If the 405U is connected to a PC and the PC will automatically set-up the 405U on start-up, then a host-connect mode should be used (modes 0 – 3). In host-connect, the 405U will start up in configuration mode.

If you want the 405U to start up in operating mode, then use the autoconnect modes (4 – 7).

### **Auto-dial or Single dial controlled mode ?**

Auto-dial operation would normally be used in a small point-to-point system.

Single-dial operation is normally used in a master-slave system where a master PC is “dialling” each remote station for data.

Both of these operations can also be achieved in transparent mode. The difference is that in the controlled mode operation, the 405U units make sure that the radio messages are transferred without errors and only the addressed remote 405U passes the message to its host.

---

## 3.8

## Operating Problems

---

Most operating problems relate to

- a serial interface problem, or
- a timing problem, or
- a radio problem.

Serial interface problems are errors in configuration - the configuration of the host serial port does not match the 405U configuration.

Timing problems relate to the timing within the host software protocol. If the host software sends a message via the 405U and requires a response from the remote device faster than the 405U can transmit it back, then there is a timing problem. The "response delay time" in the host software needs to be set long enough for the 405U to bring the response back.

Radio problems relate to an inadequate radio path, or radio interference. Before installing a system, bench test the complete system with the 405U units near each other. This test eliminates the radio path or interference as a factor, and ensures that the system will operate in the way that you want. It is not necessary to connect antennas, however a small length of wire should be inserted into the middle pin of the coaxial connector - this will act as an antenna.

If the bench test does not give adequate performance, then you need to adjust the configuration parameters. We recommend that you do not install the system until you are happy with the bench test performance.

If a system gives poor performance after it is installed, check the adequacy of the radio path - refer to the Diagnostics Section 6.

Interference will only cause a problem if the amplitude of the interference is comparable to the radio signal from the 405U units. If the interference level is relatively small, then it will not affect the performance of the system. If interference is causing a problem, try to improve the normal radio level by mounting the antennas higher or in a better location. This not always possible.

System performance may be improved by changing the following parameters :-

- If in transparent mode, try controlled mode.
- If configured for a radio data rate of 9600 bits/sec, reduce the rate to 4800 bits/sec.
- If large radio messages are being transmitted, reduce the maximum message length, and transmit the data in more messages of smaller size.

---

# Chapter Four

# CONFIGURATION

---

## 4.1

## Before Configuring

---

Configuration comprises selecting parameter values for the operation of the 405U unit. Before you start configuration, parameter settings must be decided.

The main parameters are :-

- Character type. You need to find out the character type of the host devices connected to the 405U units. The most common character type is 8 data bits, no parity, 1 start bit and 1 stop bit.
- Serial Data Rate. You need to find out the serial data rate used by the host devices. The most common serial data rate is 9600 bits/sec.
- Radio Data Rate. You need to decide what radio data rate you wish to use. It does not have to be the same as the serial data rate. Remember that the radio range for 9600 bits/sec will not be as good as that for lower data rates. Generally the data sent between process control equipment is small, and 9600 bit/sec is not required. We recommend that you use 4800 bits/sec unless your application requires the faster data rate.
- Operating mode . You need to decide which operating mode you wish to use. Modes are transparent or controlled, error-checked or no-error-check, and autoconnect or host-connect. These modes are discussed in more detail in following sections.

The other configuration parameters do not need to be selected, and are provided as a means of "fine tuning" the operation of the 405U units.

Configuration may be performed from a terminal using Hayes commands, or by using the miniature switches under the blue cover on the front of the unit.

The first step in configuration is to put the radio modem into Configuration Mode.

---

## 4.2

## Addressing

---

A 405U network comprises modules with the same "system" address. The system address is a 15 bit value (values 1 to 32767). A value of zero cannot be used. The system address is stored in two configuration registers - S registers 6 and 7 (see Section 4.3). Register S6 has the "high" byte of the system address and S7 has the low byte. The value in S7 should not be more than 127, but S6 can have values up to 255.

If you are adding another module to an existing system, set S6 and S7 to be the same values as the existing modules. If you are starting a new system, select random values for S6 and S7 and use the same values for each module.

In controlled mode, each module is also configured with a unit address between 1 and 127 - there can only be 127 modules in the one system. The unit address is configured in S register 8. In transparent mode, the unit address is not used, and there is no limit to the number of modules in a system (except for the capacity of the radio channel).

---

## 4.3

## Hayes Commands

---

The 405U unit may be configured by a host device using Hayes AT commands. Configuration may be done by a user (with a PC terminal as the host device) or it can be done automatically by a host device such as PLC or SCADA. The AT commands are ASCII messages designed for use with conventional telephone modems.

Before a 405U unit will accept Hayes commands, it must be in configuration mode. A host device may force the unit to configuration mode by sending three "escape" characters - "+++". The default escape character is "+", however this may be changed as it is one of the configuration parameters. Note that in the Host-connect operating modes, the 405U units start up in configuration mode. These modes (0, 1, 2 or 3) simulate the operation of telephone or leased-line modems, and may be used with standard host software designed with Hayes command control.

Once in configuration mode, the 405U unit will accept a string of Hayes commands, and the configuration changes made. The changes will not however be stored in permanent memory (EEPROM) unless the Hayes command for recording the configuration (AT&W) is sent. When the configuration changes are made, the module must be put back into its operating mode by using the "online" Hayes command, **ATO**

The 405U will automatically change from configuration mode to operating mode if there has been no AT command entry within a certain time. This time is one of the configuration parameters.

The following Hayes commands are accepted by the 405U unit :

### 4.3.1 Unit Reset

The **ATZ** command resets the unit as if power had been switched off and on. After power up, the configuration will be the last saved configuration - that is, the last configuration saved by the AT&W command.

### 4.3.2 Storing Configuration Parameters - Write Registers

Once configuration parameters have been changed, they can be stored to non-volatile memory with the **AT&W** command. When the unit is reset from power up or via the ATZ command, the stored parameters are restored.

### 4.3.3 Default Values - Restore Factory Defaults

The **AT&F** command will reset the configuration parameters to the default values. To reset the values and save them to nonvolatile memory, use AT&F&W. Note that a factory default reset could change the system address and unit address.

Refer to Appendix A section 1.1.10 for using the configuration switches to reset to factory defaults.

### 4.3.4 S-Registers

The E405 provides 15 S-Registers to configure the operation of the unit. S-Registers may be read using the Hayes command **ATS $n$  = xxx**, where **n** is the number of the configuration parameter, and **xxx** is the value shown below for each parameter. The entire configuration parameters may be viewed by the Hayes command **AT&V**.



**Maximum message length (S3)****ATS3 = xxx****Default = 255**

where the maximum message length in bytes is equal to twice xxx plus 10, or  $2 * (xxx) + 10$ .

For example, ATS3 = 10 gives a maximum length of 30 bytes.

The message length parameter selects the maximum length (in bytes) of the data sent in each radio message. The length may be selected between 10 bytes and 520 bytes. The message length is equal to  $2x(\text{VALUE})+10$ , where VALUE is the decimal equivalent of the 8-bit code entered.

**Serial data rate (S4)****ATS4 = xxx****Default = 8**

To select or change the serial data rate, enter the following VALUE code. The serial data rate can be different at different 405U modules in the same system. The default value is 9600 bits/sec.

| Bits/sec | xxx | Bits/sec | xxx |
|----------|-----|----------|-----|
| 50       | 0   | 2400     | 6   |
| 75       | 1   | 4800     | 7   |
| 150      | 2   | 9600     | 8   |
| 300      | 3   | 19200    | 9   |
| 600      | 4   | 38400    | 10  |
| 1200     | 5   |          |     |

**Radio data rate (S5)****ATS5 = xxx****Default = 1**

To select or change the radio data rate, enter the following VALUE code. The radio data rate should be the same at each 405U module in the same system. The default value is 4800 bits/sec.

| Bits/sec | xxx | Bits/sec | xxx |
|----------|-----|----------|-----|
| 1200     | 3   | 4800     | 1   |
| 2400     | 2   | 9600     | 0   |

**System address, high byte (S6)****ATS6 = xxx \***

where xxx is the Decimal value of the first byte of the system address.

The system address comprises two bytes. Note that the high byte cannot be more than 127. The system address will change if you force the module to factory default settings.

**System address, low byte (S7)****ATS7 = xxx \***

where xxx is the Decimal value of the second byte of the system address.

*Note\*: S6 and S7 will default back to factory settings*

**Unit address (S8)****ATS8 = xxx****Default = 1**

where xxx is the decimal value of the unit address.

Note that xxx cannot be 0 (zero) or more than 127.

In controlled mode, each module is configured with a unit address between 1 and 127 - there can only be 127 modules in the one system. In transparent mode, modules are not configured with a unit address (the value of S8 is ignored), and there is no limit to the number of modules in a system (except for the capacity of the radio channel).

### Character Type (S9)

ATS9 = x

Default = 4

The Character Type parameter configures the character format, the flow control on the serial port, and the use of DTR low power mode. The character format is the data bits, start bits, and parity configuration. The serial port flow control may be configured for to enable or disable RTS/CTS control. In all RS-485 applications and some RS-232 applications, RTS/CTS control must be disabled. DTR low power mode is explained in sections 3.1 and 4.3.5 of this manual - it is only used in modes 6 or 7 with an autodial address (that is, using the AT&Z command).

The character type in the 405U will change as soon as the ATS9 entry is made. The character type on the configuration terminal should change at the same time such that the 405U understands any subsequent commands.

**NOTE :** These values are valid for software version 1.11 and later. For earlier versions, refer to your distributor. To find out the software version, use the ATI command.

| Data Bits | Start Bits | Stop Bits | Parity | CTS/ RTS control | VALUE<br>DTR normal power mode | VALUE<br>DTR low power mode |
|-----------|------------|-----------|--------|------------------|--------------------------------|-----------------------------|
| 7         | 1          | 1         | even   | enabled          | 8                              | 40                          |
| 7         | 1          | 1         | odd    | enabled          | 9                              | 41                          |
| 7         | 1          | 2         | even   | enabled          | 11                             | 43                          |
| 7         | 1          | 2         | odd    | enabled          | 16                             | 48                          |
| 7         | 1          | 2         | none   | enabled          | 3                              | 35                          |
| 8         | 1          | 1         | even   | enabled          | 1                              | 33                          |
| 8         | 1          | 1         | odd    | enabled          | 2                              | 34                          |
| 8         | 1          | 1         | none   | enabled          | 0                              | 32                          |
| 8         | 1          | 2         | none   | enabled          | 10                             | 42                          |
| 7         | 1          | 1         | even   | disabled         | 12                             | not possible                |
| 7         | 1          | 1         | odd    | disabled         | 13                             | not possible                |
| 7         | 1          | 2         | even   | disabled         | 15                             | not possible                |
| 7         | 1          | 2         | odd    | disabled         | 20                             | not possible                |
| 7         | 1          | 2         | none   | disabled         | 7                              | not possible                |
| 8         | 1          | 1         | even   | disabled         | 5                              | not possible                |
| 8         | 1          | 1         | odd    | disabled         | 6                              | not possible                |
| 8         | 1          | 1         | none   | disabled         | 4                              | not possible                |

|   |   |   |      |          |    |              |
|---|---|---|------|----------|----|--------------|
| 8 | 1 | 2 | none | disabled | 14 | not possible |
|---|---|---|------|----------|----|--------------|

**Display Mode (S10)****ATS10 = x****Default = 3**

**NOTE :** These values are valid for software version 1.11 and later. For earlier versions, refer to your distributor. To find out the software version, use the ATI command.

| ECHO     | VERBOSE  | QUIET    | VALUE<br>"RINGING"<br>response | VALUE<br>no "RINGING"<br>response |
|----------|----------|----------|--------------------------------|-----------------------------------|
| Disabled | Disabled | Disabled | 0                              | 8                                 |
| Enabled  | Disabled | Disabled | 1                              | 9                                 |
| Disabled | Enabled  | Disabled | 2                              | 10                                |
| Enabled  | Enabled  | Disabled | 3                              | 11                                |
| Disabled | Disabled | Enabled  | 4                              | 12                                |
| Enabled  | Disabled | Enabled  | 5                              | 13                                |
| Disabled | Enabled  | Enabled  | 6                              | 14                                |
| Enabled  | Enabled  | Enabled  | 7                              | 15                                |

NOTE: This register is accessible by the "Echo" command (ATE0, or ATE1), "Quiet" command (ATQ0, or ATQ1), and "Verbose" command (ATVO, or ATV1)

Refer to section 4.3.6 for an explanation of the "Ringing" response feature.

**Command Mode Timeout (S11)****ATS11 = x****Default = 60**

Where x = timeout in seconds

If there has been no AT commands entered within this time, the 405U will automatically change from configuration mode to operating mode. If S11 is set to 0 (zero), the 405U will not automatically change, and will only change to operating mode when a ATO command is entered.

**NOTE :** These values are valid for software version 1.09 and later. For earlier versions, refer to your distributor. To find out the software version, use the ATI command.

**Transmit Hold-off Time (S12)****ATS12 = xxx****Default = 70**

where xxx is the hold-off time in 1 msec increments ( xxx = 20 for 20 msec )

A delay time may be configured such that the 405U unit will not transmit during the hold-off time after transmitting a previous message. The maximum hold-off time is 255 msec. The transmit hold-off time value is the 8-bit binary equivalent of the desired time in 1 msec increments.

**Receive Hold-off Time (S13)****ATS13 = xxx****Default = 20**

where xxx is the hold-off time in 1 msec increments ( xxx = 20 for 20 msec )



to make a connection to another 405U. If the connection is successful, data can be transferred in both directions. Either host can cancel the connection by using the ATH command ("hang-up" command). Single dial operation normally uses modes 2 or 3 for S0.

If the 405U unit is already connected to a remote module, then the connection should be cancelled by using the "hang-up" command, **ATH**

To connect to a remote module, use the "dial" command

**ATD <first repeater>,<second repeater>,. . . . ,<destination>**

For example, to set the destination address to 67 with repeater addresses 32 and 48, the command would be - **ATD32,48,67**

The module will respond with one of the following messages :-

**RINGING**            the module is in the process of connecting (only if "RINGING" is selected at S10).

**CONNECT**           the module has successfully connected

**BUSY**                the destination module is already connected to another module

**NO ANSWER**        the module was unable to connect to the destination address

If the destination address was to be 119 with no repeaters, the command would be **ATD119**.

If the master successfully connects to the slave (DCD set), then each module automatically goes on-line and data can be transferred in either direction. If there is no data transfer within the connect update time, the master will transmit a check message.

If the master is not successful when transmitting any message, it will reset the link (DCD) and will revert to command mode. If the slave is not successful in sending any message or if it does not receive data within twice the connect update time, it will reset its link status (DCD) and revert to command mode.

To cancel or "hang-up" a connection, use the **ATH** command. The ATD and ATH commands may be mixed. For example, **ATHD119** (this command also clears the previous connection before trying to make the new connection).

A hang up may also be achieved using the DTR signal. If CTS/RTS and low power operation is selected at S9, then a low DTR signal will force the 405U to hang-up. The module will not go to low power mode unless an autodial address is configured (AT&Z).

#### 4.3.7 Reading Configuration Parameters

Host devices are able to read the value of configuration parameters by using the **ATSn?** command, where "n" is the number of the configuration parameter.

#### 4.3.8 Unit Test commands - AT&Tx

Test commands are available via the command AT&Tx, where x is the test number requested. Many of these tests will be successful only during factory test. Refer to the Diagnostics section of this manual (chapter 6) for a detailed listing of the test commands available.

#### 4.3.9 Version Information - ATI

The command ATI will result in a response from the 405U module with the software version of the 405U. For example, "405U V1.09"

#### 4.3.10 Character Type - AT&Bx

This command allows configuration of the character format and flow control used on the serial port. The x value is the same as the character type command under S-register 9.

**Note:** The value of this setting is also available via S-register S9

#### 4.3.11 Character Type - AT&Mx

This command allows configuration of the operating mode. The x value is the same as the character type command under S-register 0.

**Note:** The value of this setting is also available via S-register S0.

#### 4.3.12 Verbose mode control, Local Echo control, and Quiet mode

The following commands from the host control the responses of the 405U unit to the Hayes commands.

|             |                       |
|-------------|-----------------------|
| <b>ATV0</b> | numeric responses     |
| <b>ATV1</b> | verbal responses      |
| <b>ATQ0</b> | response displayed    |
| <b>ATQ1</b> | No response displayed |
| <b>ATE0</b> | disable local echo    |
| <b>ATE1</b> | enable local echo     |

Note: the values of these settings are also available via S-register S10.

#### 4.3.13 Responses

The 405U modules provide responses to the Hayes commands. The responses will be either in verbal (ASCII) or numeric, depending on the "ATV" configuration. The following responses will be issued by the module :-

| <b>VERBAL</b> | <b>NUMERIC</b> | <b>MEANING</b>                            |
|---------------|----------------|---|
| OK            | 0              | Command accepted                          |
| CONNECT       | 1              | Connected to remote unit                  |
| NO CARRIER    | 3              | Connection lost to remote unit            |
| ERROR         | 4              | Invalid command                           |
| BUSY          | 7              | Destination unit already connected        |
| NO ANSWER     | 8              | No response from destination address      |
| RINGING       | 13             | Attempting to connect to destination unit |

## 4.4 Configuration Examples

### Transparent Mode

#### Extending a PLC Network

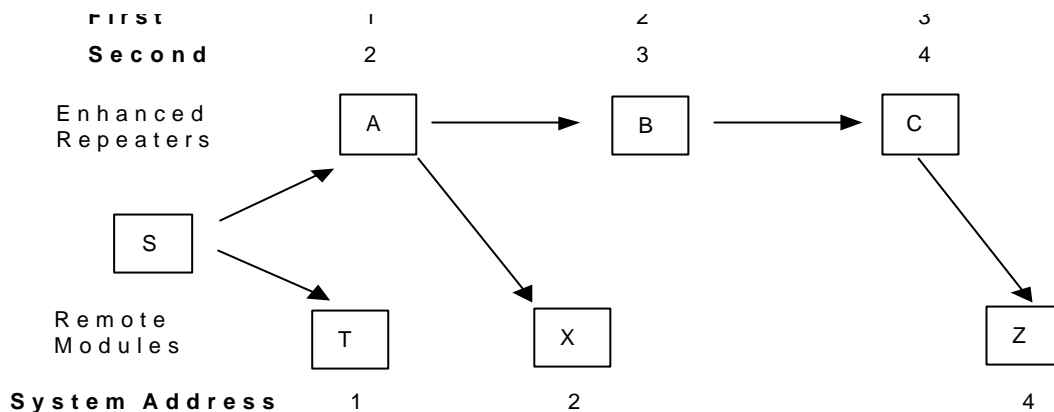

#### Unit No. 1 Configuration

Set the module to factory default settings: AT&F

Set the system address to a random number: AT&S6 = 38      AT&S7 = 92

Set the serial data rate to 38400: AT&S4 = 10

Set the radio data rate to 9600: AT&S5 = 0

Set the character type to 7,1,2,even: AT&S9 = 15

Exit and save the configuration: AT&W      ATO

The operating mode will already be in transparent mode from the factory default settings. The other default values for the other parameters will likely be OK.

#### Repeater Configuration

Set the module to factory default settings: AT&F

Set the system address to the same random number: AT&S6 = 38      AT&S7 = 92

Set the radio data rate to 9600: AT&S5 = 0

Set the operating mode to Transparent Repeater: AT&S0 = 8

Exit and save the configuration: AT&W      ATO

#### Unit No. 2 Configuration

Set the module to factory default settings: AT&F

Set the system address to the same random number: AT&S6 = 38      AT&S7 = 92

Set the radio data rate to 9600: AT&S5 = 0

Set the character type to 7,1,2,even: AT&S9 = 15



**Module #100**

Note that #100 is the master unit for a link between #100 and #101, It is also acting as repeater in the #1 to #3 link. The system address for #100 and #101 must be the same as the other modules so that #100 can act as a repeater.

|   |            |           |
|---|------------|-----------|
| Set the module to factory default settings:       | AT&F       |           |
| Set the system address to the same random number: | ATS6 = 17  | ATS7 = 50 |
| Set the unit address to 100                       | ATS8 = 100 |           |
| Set the operating mode to controlled mode         | ATS0 = 7   |           |
| Set the autodial address to 101                   | AT&Z101    |           |
| Exit and save the configuration                   | AT&W       | ATO       |

The configuration for #101 is not shown as it is not part of the active link.

## Chapter Five

## SPECIFICATIONS

|                          |   |  |
|--------------------------|---|--|
| <b>General</b>           |   |  |
| EMC specification        | EN55022 (CISPR 22)<br>EN 50082-1,<br>EN 300 683<br>AS 3548  | 89/336/EEC   |
| Radio specification      | MPT 1329 UK<br>EN-300-220<br>AS 4268.2 AUST<br>RFS29 NZ     | 458 MHz, 500 mW EIRP<br>430 - 450 MHz, 10 - 500 mW<br>472 MHz, 100 mW EIRP<br>458 MHz, 500 mW EIRP |
| Housing                  | 130 x 185 x 60mm<br>DIN rail mount                          | Powder-coated, extruded aluminium  |
| Terminal blocks          | Removable   | Suitable for 2.5sqmm conductors  |
| LED indication           | OK operation, Serial RX and TX, Radio RX and TX, DCD active |  |
| Operating Temperature    | -20 to 60 degrees C   |  |
| <b>Power Supply</b>      |   |  |
| Nominal supply           | 12VDC or 24VDC  |  |
| 12V supply               | 11.3 - 15 VDC   | Overvoltage and reverse voltage protected  |
| 24V supply               | 18 - 28 VDC   | Overvoltage and reverse voltage protected  |
| Current Drain @ 12VDC    | 150 mA quiescent<br>100mA low power mode                    | During transmission 500mA  |
| Current Drain @ 24VDC    | 120 mA quiescent<br>80mA low power mode                     | During transmission 300mA  |
| <b>Radio Transceiver</b> |   |  |
| Single channel           | synthesised, selectable band 4MHz                           | Direct frequency modulation  |
| Frequency                | 405 - 490 MHz<br>220 – 235 MHz                              | 12.5 kHz channel spacing   |
| Transmit power           | 10 - 500 mW<br>5W   | 405-490 MHz<br>220 – 235 MHz   |

|  |  |  |
|--|--|--|
| Spurious emissions                             | RX - <-57 dBm<br>TX - <-37 dBm                               |  |
| Frequency Stability                            | +/- 1.0 kHz  |  |
| Receiver Sensitivity                           | 0.4uV at 12dB SINAD  |  |
| Signal detect / RSSI                           | -120 to -80 dBm  |  |
| Expected line-of-sight range<br>@ 4800 bit/sec | 2 km @ 10mW EIRP<br>5 km @ 100mW EIRP<br>10 km @ 500 mW EIRP | Range may be extended by up to 5 intermediate modules as repeaters, in controlled mode             |
| Antenna Connector                              | Female BNC coaxial   | Protected by gas discharge surge arrester  |
| <b>Serial Ports</b>                            |  |  |
| RS232 Port                                     | DB9 female DCE   | RTS/CTS/DCD hardware signals provided  |
| RS485 Port                                     | 2 pin terminal block   | Typical distance 1 - 2 km  |
| Data rate (bit/sec) - configurable             | 50, 75, 150, 300, 600, 1200, 2400, 4800, 9600, 19200, 38400  |  |
| Byte format                                    | 7 or 8 data bits   | Stop/start/parity bits configurable  |
| <b>Output Signal</b>                           |  |  |
| DCD (communications) active                    | FET output, 30 VDC<br>500mA                                  | In transparent mode:<br>always ON.<br><br>In controlled mode:<br>ON when radio link is established |
| <b>System Parameters</b>                       |  |  |
| Operating modes                                | Transparent mode<br><br>Controlled mode                      | Broadcast system<br><br>Addressed communications with acknowledged                                 |
| System address                                 | Configurable 15 bit  |  |
| User Configuration                             |  | Hayes commands from host device.<br><br>Or via on-board DIP switches                               |

# Chapter Six TROUBLESHOOTING

## 6.1 Diagnostics Chart

| INDICATOR                     | CONDITION                                      | MEANING   |
|-------------------------------|--|---|
| OK LED OFF                    | Continuously                                   | <ul style="list-style-type: none"> <li>Power supply failure</li> <li>CPU failure</li> </ul>   |
| OK LED ON                     | Continuously                                   | <ul style="list-style-type: none"> <li>Normal Operation</li> </ul>  |
| Radio TX LED ON               | Flashes briefly                                | <ul style="list-style-type: none"> <li>Radio transmitting</li> </ul>  |
| Radio RX LED ON               | GREEN flash<br>RED flash                       | <ul style="list-style-type: none"> <li>Radio receiving data</li> <li>Weak radio signal</li> </ul>   |
| Serial RX LED ON              | GREEN flash<br>RED flash<br>GREEN continuously | <ul style="list-style-type: none"> <li>Serial Port Receiving</li> <li>CTS low</li> <li>Configuration Mode</li> </ul>                              |
| Radio RX and Serial RX LED ON | RED flash for 10 secs after power up           | <ul style="list-style-type: none"> <li>Configuration corruption (EEPROM failure)</li> </ul>   |
| Serial TX LED ON              | Flashes briefly                                | <ul style="list-style-type: none"> <li>Serial port transmitting</li> </ul>  |
| DCD LED ON                    | Continuously                                   | <ul style="list-style-type: none"> <li>In transparent mode, always on.</li> <li>In controlled mode, a radio link has been established.</li> </ul> |

The green OK LED on the front panel indicates correct operation of the unit. This LED extinguishes on failure as described above. When the OK LED extinguishes shutdown state is indicated. On processor failure, or on failure during startup diagnostics, the unit shuts down, and remains in shutdown until the fault is rectified.

## 6.2 Test Functions

### 6.2.1 Radio Testing using Tone Reversals

This function allows the unit to be configured to continuously transmit a sequence of alternate zeros and ones on the radio. This function provides the facility to check VSWR of antennas during installation, as well as checking the fade margin of the path between two units (see below - received signal strength indication).

The tone reversals function is initiated by setting all of the DIL switches to ON, and holding down the red button for approximately 5 seconds (until the Serial RX LED indicates RED continuously). On releasing the button, the RX LED will flash continuously, and the TX LED will light, indicating that the radio transmitter is on.

### 6.2.2 Diagnostic Functions - AT&Tx

To aid in the checking and setup of the 405U unit diagnostic functions in the 405U are provided using the standard Hayes AT commands. Several of these functions are used during factory test, and will not work correctly if the unit is not connected to the factory test jig.

The table below outlines the functions of the various tests:

| Test Command | Function                         |
|--------------|----------------------------------|
| AT&T0        | Factory test only                |
| AT&T1        | Factory test only                |
| AT&T2        | Factory test only                |
| AT&T3        | Factory test only                |
| AT&T4        | Factory test only                |
| AT&T5        | Internal RAM test                |
| AT&T6        | Nonvolatile Memory (EEPROM) test |
| AT&T7        | Configuration Switch test        |
| AT&T8        | Received Signal Strength Display |
| AT&T9        | Transmit Tone reversals          |
| AT&TA        | BER Test - Master                |
| AT&TB        | BER Test - Slave                 |
| AT&TC        | BER Test – Two direction         |

*The tests most useful for diagnosing system problems are “received signal strength display” and “transmit tone reversals”.*

#### AT&T9 - Transmit Tone Reversals

This provides the same function as described above (Tone Reversals). This function may be used to check VSWR of antennas, and may be used in conjunction with the Signal option (described below) to check the path between two 405U units.

#### AT&T8 - Received Signal Strength Display

This option provides for testing the radio path between two 405U units. Although a pair of units may communicate successfully, radio communication may be affected by a range of influences, including atmospheric conditions, changing landscape, degradation of antennas or co-axial cable, low battery voltage etc. Fade margin is an indication of how far a radio path can deteriorate before reliable communication becomes unreliable.

When using this feature, the current value of the received signal strength is displayed in dBm (decibels referenced to 1 mW). This value is updated every half second. To check the radio path between two units, select the signal option at the local unit. The remote unit may then be set up for tone reversals (refer 1 above) and the signal level read from the computer screen. We have selected a bit error rate (BER) of 1 in 300 as the point at which unreliable communications occurs. The following table lists the minimum signal required for reliable communications (BER > 1 in 300). A system with the minimum signal level will not stay reliable under all conditions, because of changing factors such as environmental conditions. A fade margin of at least 15 dB should be allowed for to take account of these factors. The table also lists our recommended minimum signal level, taking this margin into account.

| Radio Baud Rate | Minimum signal for BER<br>= 1 in 300 | Recommended minimum<br>signal |
|-----------------|--------------------------------------|-------------------------------|
| 9600            | -100 dBm                             | -85 dBm                       |
| 4800            | -107 dBm                             | -92 dBm                       |

In areas experiencing radio interference or high background noise, reliable communications may not be achievable even with this signal level. To determine if interference is occurring, the signal option may be selected **without any other 405U units active**. In a normal radio environment, a reading of at most -110 dBm should be displayed. If a reading above this value is displayed (for example -100 dBm), then the received signal strength from the remote should be **at least 15 dB higher** than the background noise for reliable communication.

**Example:**

AT&T8      ***Displayed signal level of background noise/interference***

RSSI Display - press a key to exit

-88 dBm

AT&T8      ***Minimum signal level for reliable comms***

RSSI Display - press a key to exit

-73 dBm

When using directional antennas (YAGI antennas) this feature may be used to align the antenna in the correct direction by selecting the peak signal when moving the antenna. Setup the remote unit to transmit tone reversals as described above, and observe the signal indication while adjusting the orientation of the antenna. A peak in signal level indicates optimum orientation of the antenna.

### 6.2.3 Bit Error Rate Test (BER)

BER may be tested in one direction by typing AT&TA (BER master) at the sending unit and typing AT&TB (BER slave) at the receiving unit. The sending unit will repeatedly send pseudo-random frames, and the receiving unit will check these frames for errors. If a terminal is connected to the sending unit, the pseudo-random data is displayed as it is transmitted. If a terminal is connected to the receiving unit, then the test results are displayed.

An example of the receiving unit's display is here.

| <b>Test</b> | <b>Errors</b> | <b>Extra</b> | <b>Level</b> | <b>TotErr</b> | <b>TotTest</b> |
|-------------|---------------|--------------|--------------|---------------|----------------|
| 109         | 0             | 0            | -77dBm       | 3             | 109 kbit       |

|                |   |  |
|----------------|---|--|
| <b>Test</b>    | - | the sequence number of the last received frame   |
| <b>Errors</b>  | - | the number of bit errors in the last received frame  |
| <b>Extra</b>   | - | any extra characters at the end of the frame (negative numbers indicate frame dropped out early) |
| <b>Level</b>   | - | the RSSI level when the frame was received.  |
| <b>TotErr</b>  | - | The total errors received during this test.  |
| <b>TotTest</b> | - | The total number of bits sent (in 1000's)  |

Occasionally during testing, the following may be displayed:

| <b>Test</b> | <b>Errors</b> | <b>Extra</b> | <b>Level</b> | <b>TotErr</b> | <b>TotTest</b> |
|-------------|---------------|--------------|--------------|---------------|----------------|
|             |               |              |              |               |                |

**Bad Header**

This indicated that the header information has been corrupted. Corrupted headers do not contribute to the bit errors, which are calculated only on the 1,000 bit frame.

BER testing may also be performed in both directions simultaneously. In this case, a remote module is set up to Transparent mode repeater operation, (ATS0=8) and the BER test is performed on the local module using the command AT&TC (loopback Bit Error Test). In this case, the display is identical to the display on the BER slave unit above, but the displayed bit errors are a total for the round trip, so will be the sum of the bit errors in both directions.

---

## Chapter Seven WARRANTY & SERVICE

We are pleased that you have purchased this product. Your purchase is guaranteed against defects for a 365 day warranty period, commencing from the date of purchase.

This warranty does not extend to:

- Failures caused by the operation of the equipment outside the particular product's specification.
- use of the 405U module not in accordance with this User Manual, or
- abuse, misuse, neglect or damage by external causes, or
- repairs, alterations, or modifications undertaken other than by an authorised Service Agent.

Full product specifications and maintenance instructions are available from your Service Agent, your source of purchase, or from the master distributor in your country upon request and should be noted if you are in any doubt about the operating environment for your equipment purchase

In the unlikely event of your purchase being faulty, your warranty extends to free repair or replacement of the faulty unit, after its receipt at the master distributor in your country. Our warranty does not include transport or insurance charges relating to a warranty claim.

This warranty does not indemnify the purchaser of products for any consequential claim for damages or loss of operations or profits.

Should you wish to make a warranty claim, or obtain service, please forward the module to the nearest authorised Service Agent along with proof of purchase. For details of authorised Service Agents, contact your sales distributor.

# Appendix A Switch Configuration

## 1.0

## Introduction

In order to configure the 405U unit, or to change the configuration, the unit must be placed into Configuration Mode. When in this mode, the unit will not operate as transparent or controlled mode.

Module configuration may be performed using the on-board miniature (DIP) switches or from the host device using Hayes AT command codes (refer to Section 4.3).

In order to avoid radio interference between adjacent 405U networks, a "system address" is required to be configured. Each module within the one network **must** have the same system address. The system address may be any number between 1 and 32 767.

To simplify matters, the system address may be just an arbitrary pattern of off and on switches ("0"s and "1"s) - it is not important what the actual system address value is - as long as each module in the network has the same switch pattern for the system address. A system address of zero (all 0's) is not acceptable.

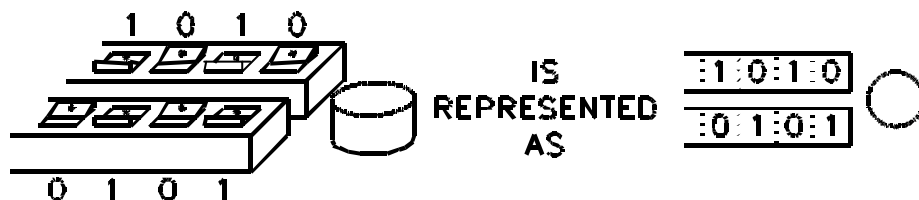

**NOTE:**

The configuration used in your system should be recorded for future reference. This information will be required when the unit is initially configured, if a unit is replaced, if the system is to be expanded, or if units are tested with the internal Self Test configuration. Configuration record sheets are provided at the end of this manual. These sheets should be used to assist in planning the network for your application and to have the data readily available for entry.

Entering a system address puts the 405U in Configuration Mode:

- Carefully remove the blue plastic cover in the centre of the module to reveal the switches and red pushbutton underneath.

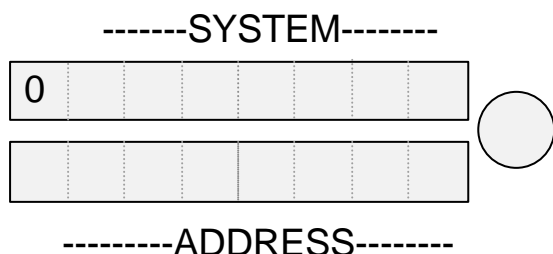

- Set the chosen system address on the DIP switches as shown. Make sure the switch marked '0' is set to '0'. Other switches can be in any chosen position.
- Press the red button for approx. 3 seconds - until the *Serial RX* LED indicates RED.
- The *Serial RX* LED will indicate GREEN on release of the button indicating the unit is in "Configuration Mode"

Once the module is in configuration mode, transparent or controlled mode may be selected. This is achieved by entering in another switch pattern. If transparent mode is selected, no further configuration is required, and the module will automatically exit configuration mode. If controlled mode is selected, further entries are required for the addressing of the communications link.

### 1.0.1 Default Configuration

The default configuration is the configuration set in the factory. When you receive new modules, they will have this configuration. The default configuration is transparent mode without error-checking, autoconnect mode, with serial data rates of 9600 bits/sec, and radio data rate of 4800 bit/sec. The serial ports will be set up for a byte format of 8 data bits, 1 start bit, 1 stop bit and no parity. Further details of default settings are included in Appendix A – Section 1.1.10.

### 1.0.2 Transparent Mode

To select transparent mode the following switch pattern is entered after the system address is entered :-

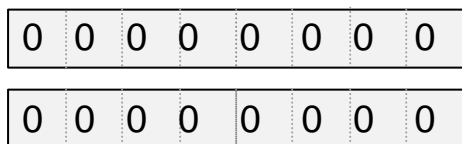

- **First enter the system address**
- Enter the switch pattern
- Configuration mode will automatically exit and the *RX* LED will reset.

The operating mode will be set to mode 4 (Transparent mode without error check). Refer to Configuration Parameters in Appendix A – Section 1.1.

### 1.0.3 Controlled Mode

In controlled mode, each module within a network must be configured with an individual **unit address**. **Each module must have a unique unit address within the one system**. Each controlled mode system may have up to 127 modules. Addresses may be in the range 1 to 127. Note that address 0 is not accepted - if this address is entered, the module exits configuration mode and you must start configuration again. This address is coded in binary on the DIP switches. Appendix B lists the switch code for each address between 1 and 127.

To configure controlled mode, switch patterns are entered consecutively with the module unit address, any repeater addresses and the destination address. These switch patterns are entered after the system address has been entered. If more than one repeater is used in the radio link, then each repeater address is entered in order, starting with the first repeater and then the next repeater and so on. Up to five repeater addresses may be entered. If only one repeater is used, then only one repeater address is entered. If three are used, then three repeater addresses are entered - etc. The destination address is always the last address entered. If there are no repeaters used, then the destination address is entered immediately after the unit address. After the destination address is entered, a switch pattern with all "0"s (all the switches off) is entered. The module then exits configuration mode.

**Note that repeater and destination addresses are only entered for the “master” unit in each link.** For “slave” units, only the unit address is entered. For modules which will just act as a repeater unit, just a unit address need be entered. For these modules, enter the exit pattern of all zero’s after the unit address.

To select controlled mode the following switch pattern is entered after the system address has been entered.



- **First enter the system address**
- Enter the unit address
- Enter the repeater addresses (if any) in order, and then enter the destination address.

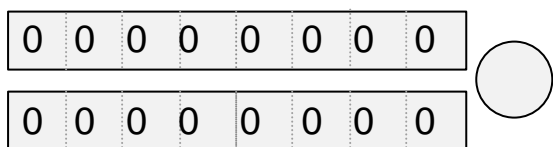

- **When all of the addresses have been entered**
- Enter all 0’s
- Configuration mode will automatically exit and the RX LED will reset.

The operating mode will be set to Controlled Mode with Error-Checking (mode 7) - refer to Appendix A – Section 1.1, Configuration Parameters.

**Example**

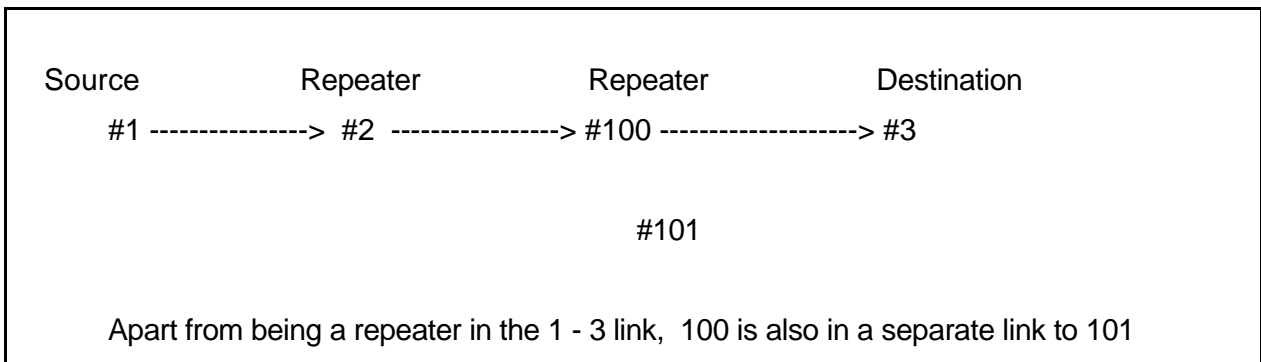

**Module #1 Configuration**

Module #1 is configured as the master unit .

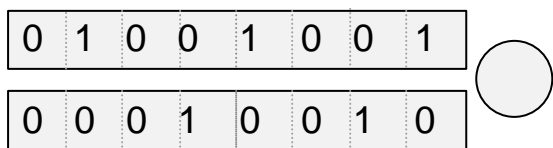

- System address 100 1001 0001 0010.

|   |   |   |   |   |   |   |   |
|---|---|---|---|---|---|---|---|
| 0 | 0 | 0 | 0 | 0 | 0 | 0 | 1 |
| 0 | 0 | 0 | 0 | 0 | 0 | 0 | 1 |



- Unit address is 0000001 (#1)

|   |   |   |   |   |   |   |   |
|---|---|---|---|---|---|---|---|
| 0 | 0 | 0 | 0 | 0 | 0 | 0 | 1 |
| 0 | 0 | 0 | 0 | 0 | 0 | 1 | 0 |



- First repeater address is 0000010 (#2)

|   |   |   |   |   |   |   |   |
|---|---|---|---|---|---|---|---|
| 0 | 0 | 0 | 0 | 0 | 0 | 0 | 1 |
| 0 | 1 | 1 | 0 | 0 | 1 | 0 | 0 |



- Second repeater address is 1100100 (#100)

|   |   |   |   |   |   |   |   |
|---|---|---|---|---|---|---|---|
| 0 | 0 | 0 | 0 | 0 | 0 | 0 | 1 |
| 0 | 0 | 0 | 0 | 0 | 0 | 1 | 1 |



- Destination address is 0000011 (#3)

|   |   |   |   |   |   |   |   |
|---|---|---|---|---|---|---|---|
| 0 | 0 | 0 | 0 | 0 | 0 | 0 | 0 |
| 0 | 0 | 0 | 0 | 0 | 0 | 0 | 0 |



- Configuration complete

**Module #2 Configuration**

Module #2 is the first repeater. As there is no host device connected, a destination address is not required.

|   |   |   |   |   |   |   |   |
|---|---|---|---|---|---|---|---|
| 0 | 1 | 0 | 0 | 1 | 0 | 0 | 1 |
| 0 | 0 | 0 | 1 | 0 | 0 | 1 | 0 |



- System address 100100100010010.

|   |   |   |   |   |   |   |   |
|---|---|---|---|---|---|---|---|
| 0 | 0 | 0 | 0 | 0 | 0 | 0 | 1 |
| 0 | 0 | 0 | 0 | 0 | 0 | 1 | 0 |



- Unit address is 0000010 (#2)

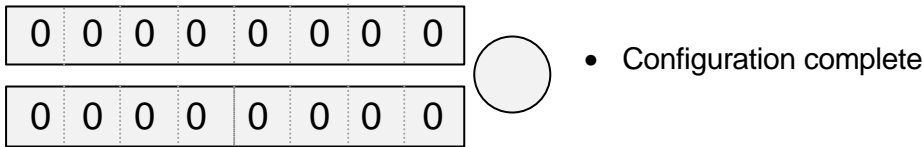

**Module #100 Configuration**

Module #100 is the second repeater in the link between #1 and #3. It also has a host device and transmits data to #101. It is configured as the “master” unit for the #100 - #101 link. As it has the unit address #100, it will also act as a repeater for #1 - #3. Note that the system address for #100 and #101 has to be the same as #1 and #3.

If module #100 was the “slave” unit for the #100 - #101 link, then only the unit address would be required for the #100 configuration.

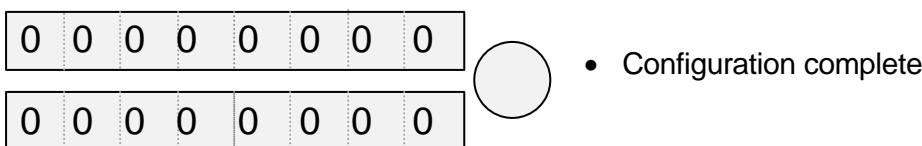
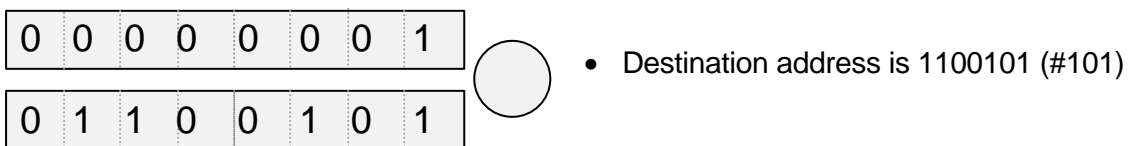
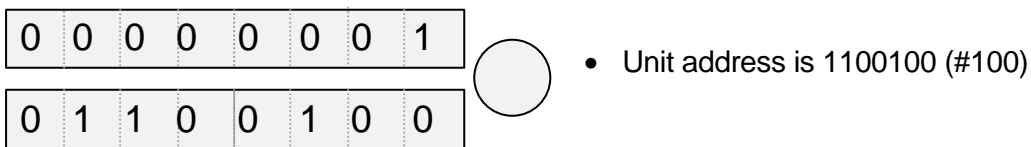
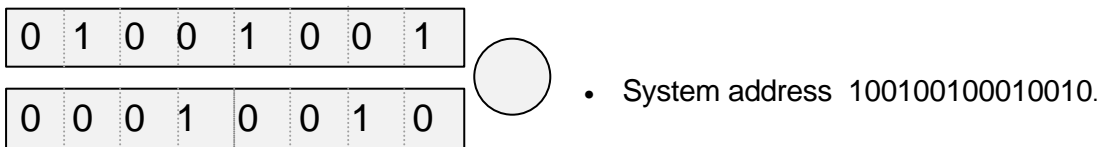



**Module #3 Configuration**

As module #3 is the “slave” unit for this link, only the unit address is required for the configuration.

|   |   |   |   |   |   |   |   |
|---|---|---|---|---|---|---|---|
| 0 | 1 | 0 | 0 | 1 | 0 | 0 | 1 |
| 0 | 0 | 0 | 1 | 0 | 0 | 1 | 0 |

- System address 100100100010010.

|   |   |   |   |   |   |   |   |
|---|---|---|---|---|---|---|---|
| 0 | 0 | 0 | 0 | 0 | 0 | 0 | 1 |
| 0 | 0 | 0 | 0 | 0 | 0 | 1 | 1 |

- Unit address is 0000011 (#3)

|   |   |   |   |   |   |   |   |
|---|---|---|---|---|---|---|---|
| 0 | 0 | 0 | 0 | 0 | 0 | 0 | 0 |
| 0 | 0 | 0 | 0 | 0 | 0 | 0 | 0 |

- Configuration complete

## 1.1Configuration Parameters

Configuration parameters may be configured or changed at any time by entering the appropriate switch code and pressing the red button continuously until the *Serial RX* LED indicates RED. When the red button is released, the *RX* LED will return to normal. The 405U module will reset and start-up as if power had been disconnected.

Each parameter has a default value which is set in the factory. All of the parameters do not need to be set - only those which you wish to change..

Each switch entry will be of the following pattern :-

--PARAM--

|   |   |   |   |  |  |  |  |
|---|---|---|---|--|--|--|--|
| 1 | 0 | 0 | 0 |  |  |  |  |
|   |   |   |   |  |  |  |  |

- Enter the code with the parameter code (PARAM) and the parameter value (VALUE) chosen and press button until *RX* LED lights.

-----VALUE-----

### 1.1.1 Operating Mode

|      |                 | PARAM = 0 0 0 0                      | Default = 0 0 0 0 0 1 0 0 |
|------|-----------------|--------------------------------------|---------------------------|
| Mode | Value           | Option                               | Connect Mode              |
| 0    | 0 0 0 0 0 0 0 0 | Transparent mode without error-check | Host                      |
| 1    | 0 0 0 0 0 0 0 1 | Transparent mode with error-check    | Host                      |
| 2    | 0 0 0 0 0 0 1 0 | Controlled mode without error-check  | Host                      |
| 3    | 0 0 0 0 0 0 1 1 | Controlled mode with error-check     | Host                      |
| 4    | 0 0 0 0 0 1 0 0 | Transparent mode without error-check | Auto                      |
| 5    | 0 0 0 0 0 1 0 1 | Transparent mode with error-check    | Auto                      |
| 6    | 0 0 0 0 0 1 1 0 | Controlled mode without error-check  | Auto                      |
| 7    | 0 0 0 0 0 1 1 1 | Controlled mode with error-check     | Auto                      |
| 8    | 0 0 0 0 1 0 0 0 | Transparent mode repeater            | Auto                      |

Host connect modes are suitable for use with host devices that can drive leased-line or dial-up modems. Units in Host-connect mode power-up in Configuration Mode. They require a Hayes command to make a connection. eg. ATO for Leased-line or ATDxx - see 4.3 Hayes Commands.

Autoconnect modes will automatically establish a connection on power-up and automatically try to re-establish a connection if it is lost.

Note that the programming of a system, unit or destination address using the DIL switches will cause the unit to default to Mode 4 transparent mode or Mode 7 controlled mode. For this reason, the Operating Mode parameter must be programmed (if mode 4 or mode 7 are unsuitable) **after** entering the address information.

### 1.1.2 Tail Time

PARAM = 0 0 0 1      Default = 0 0 0 0 0 0 0 0

A tail time may be configured which keeps the radio channel open at the end of each message. The maximum tail time is 2.55 seconds. The tail time value is the 8-bit binary equivalent of the desired time in 10 msec increments. Hence for a desired tail time of 100 msec, a VALUE code of ten (00001010) is entered. For the maximum time of 2.55 secs, a VALUE code of 255 (11111111) is entered. The default tail time is zero seconds - that is, no tail time. Appendix A lists the 8-bit patterns for each value between 0 and 255.

### 1.1.3 Message Length

PARAM = 0 0 1 1      Default = 1 1 1 1 1 1 1 1

The message length parameter selects the maximum length (in bytes) of the data sent in each radio message. The length may be selected between 10 bytes and 520 bytes. The message length is equal to  $2x(\text{VALUE})+10$ , where VALUE is the decimal equivalent of the 8-bit code entered.

Hence for a desired message of 10 bytes, a VALUE code of zero (00000000) is entered. For the maximum length of 520 bytes, a MESSL code of 255 (11111111) is entered. The default message length is 520 bytes.

#### 1.1.4 Serial Data Rate

PARAM = 0 1 0 0      Default = 0 0 0 0 1 0 0 0

To select or change the serial data rate, enter the following VALUE code. The serial data rate can be different at different 405U modules in the same system. The default value is 9600 bits/sec.

| Serial Data Rate<br>(bits/sec) | VALUE           | Serial Data Rate<br>(bits/sec) | VALUE           |
|--------------------------------|-----------------|--------------------------------|-----------------|
| 50                             | 0 0 0 0 0 0 0 0 | 2400                           | 0 0 0 0 0 1 1 0 |
| 75                             | 0 0 0 0 0 0 0 1 | 4800                           | 0 0 0 0 0 1 1 1 |
| 150                            | 0 0 0 0 0 0 1 0 | 9600                           | 0 0 0 0 1 0 0 0 |
| 300                            | 0 0 0 0 0 0 1 1 | 19200                          | 0 0 0 0 1 0 0 1 |
| 600                            | 0 0 0 0 0 1 0 0 | 38400                          | 0 0 0 0 1 0 1 0 |
| 1200                           | 0 0 0 0 0 1 0 1 |                                |                 |

#### 1.1.5 Radio Data Rate

PARAM = 0 1 0 1      Default = 0 0 0 0 0 0 0 1

To select or change the radio data rate, enter the following VALUE code. The radio data rate should be the same at each 405U module in the same system. The default value is 4800 bits/sec.

| Radio Data Rate<br>(bits/sec) | VALUE           | Radio Data Rate<br>(bits/sec) | VALUE           |
|-------------------------------|-----------------|-------------------------------|-----------------|
| 1200                          | 0 0 0 0 0 0 1 1 | 4800                          | 0 0 0 0 0 0 0 1 |
| 2400                          | 0 0 0 0 0 0 1 0 | 9600                          | 0 0 0 0 0 0 0 0 |

#### 1.1.6 Transmit Hold-off Time

PARAM = 1 1 0 0      Default = 0 0 1 0 1 0 0 0

A delay time may be configured such that the 405U unit will not transmit during the hold-off time after transmitting a previous message. The maximum hold-off time is 255 msec. The transmit hold-off time value is the 8-bit binary equivalent of the desired time in 1 msec increments. Hence for a desired hold-off time of 10 msec, a VALUE code of ten (00001010) is entered. For the maximum time of 255 msec, a VALUE code of 255 (11111111) is entered. The default tail time is 40 msec. Appendix B lists the 8-bit patterns for each value between 0 and 255.

### 1.1.7 Receive Hold-off Time

PARAM = 1 1 0 1      Default = 0 0 0 1 0 1 0 0

A delay time may be configured such that the 405U unit will not transmit a message during the hold-off time after receiving a message. The maximum hold-off time is 255 msec. The receive hold-off time value is the 8-bit binary equivalent of the desired time in 1 msec increments. Hence for a desired hold-off time of 10 msec, a VALUE code of ten (00001010) is entered. For the maximum time of 255 msec, a VALUE code of 255 (11111111) is entered. The default tail time is 20 msec. Appendix B lists the 8-bit patterns for each value between 0 and 255.

### 1.1.8 Character Type

PARAM = 1 0 0 1      Default = 0 0 0 0 0 1 0 0

To select or change the data character type, enter the following VALUE code. The character type should match the type of data handled by the host device connected to that 405U module. The character type is normally the same at each 405U module in the same system.

The Character Type parameter configures both the character format and the flow control on the serial port. The character format comprises the number of data bits, start bits, and parity configuration. The serial port flow control may be configured to enable or disable RTS/CTS control. In all RS-485 applications and some RS-232 applications, RTS/CTS control must be disabled.

The default type is 8 data bits, 1 start bit, 1 stop bit, no parity, with disabled RTS/CTS.

**NOTE: These values are valid for software Versions 1.11 or later, with configurations requiring DTR Low Power Mode only. Modules requiring DTR Normal Power Mode will need to be configured using Register S9 - Character Type.**

| Data Bits | Start Bits | Stop Bits | Parity | CTS/ RTS control | VALUE           |
|-----------|------------|-----------|--------|------------------|-----------------|
| 8         | 1          | 1         | none   | enabled          | 0 0 0 0 0 0 0 0 |
| 8         | 1          | 1         | even   | enabled          | 0 0 0 0 0 0 0 1 |
| 8         | 1          | 1         | odd    | enabled          | 0 0 0 0 0 0 1 0 |
| 7         | 1          | 2         | none   | enabled          | 0 0 0 0 0 0 1 1 |
| 7         | 1          | 1         | even   | enabled          | 0 0 0 0 1 0 0 0 |
| 7         | 1          | 1         | odd    | enabled          | 0 0 0 0 1 0 0 1 |
| 8         | 1          | 2         | none   | enabled          | 0 0 0 0 1 0 1 0 |
| 7         | 1          | 2         | even   | enabled          | 0 0 0 0 1 0 1 1 |
| 7         | 1          | 2         | odd    | enabled          | 0 0 0 1 0 0 0 0 |
| 8         | 1          | 1         | none   | disabled         | 0 0 0 0 0 1 0 0 |
| 8         | 1          | 1         | even   | disabled         | 0 0 0 0 0 1 0 1 |
| 8         | 1          | 1         | odd    | disabled         | 0 0 0 0 0 1 1 0 |
| 7         | 1          | 2         | none   | disabled         | 0 0 0 0 0 1 1 1 |

| Data Bits | Start Bits | Stop Bits | Parity | CTS/ RTS control | VALUE           |
|-----------|------------|-----------|--------|------------------|-----------------|
| 7         | 1          | 1         | even   | disabled         | 0 0 0 0 1 1 0 0 |
| 7         | 1          | 1         | odd    | disabled         | 0 0 0 0 1 1 0 1 |
| 8         | 1          | 2         | none   | disabled         | 0 0 0 0 1 1 1 0 |
| 7         | 1          | 2         | even   | disabled         | 0 0 0 0 1 1 1 1 |
| 7         | 1          | 2         | odd    | disabled         | 0 0 0 1 0 1 0 0 |

**1.1.9 Connect Update Time**

PARAM = 1 1 1 0      Default = 0 1 1 0 0 1 0 0

In controlled mode, the 405U unit will transmit a “connect” message if there has been no activity on the radio channel for the update time. The connect update time value is the 8-bit binary equivalent of the desired time in 0.1 minute increments. Hence for a desired hold-off time of 1 minute, a VALUE code of ten (00001010 ) is entered. For the maximum time of 25.5 minutes, a VALUE code of 255 (11111111) is entered. The default update time is 10 minutes. Appendix B lists the 8-bit patterns for each value between 0 and 255.

**1.1.10 Reset to Factory Default Settings**

The following switch pattern will reset the configurations to the factory default values. Note that this also includes the original factory set system address.

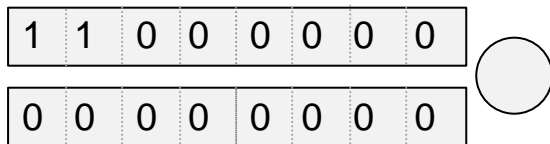

- Enter the code with and press button until *Serial RX* LED indicates RED.

**1.2 Configuration Example**

**Transparent Mode**

**Extending a PLC Network**

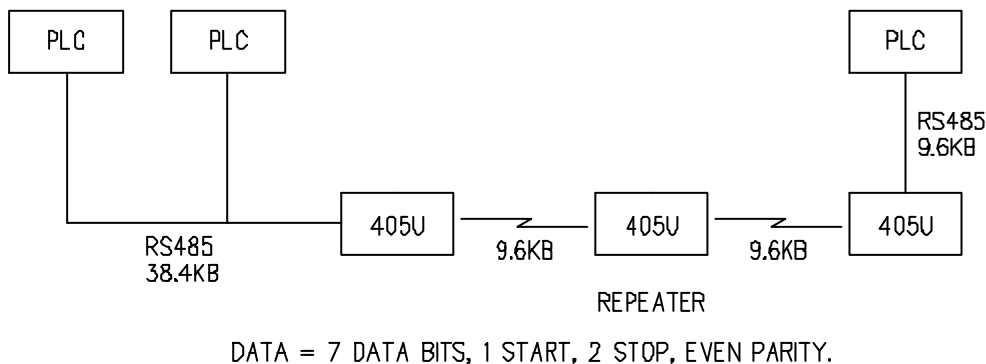

**Unit No. 1 Configuration**

|   |   |   |   |   |   |   |   |
|---|---|---|---|---|---|---|---|
| 0 | 0 | 0 | 1 | 0 | 1 | 0 | 1 |
| 0 | 0 | 0 | 1 | 0 | 1 | 0 | 1 |



- Set the System Address
- Press the red button for approx. 3 seconds - until the *Serial RX* LED indicates RED.

|   |   |   |   |   |   |   |   |
|---|---|---|---|---|---|---|---|
| 0 | 0 | 0 | 0 | 0 | 0 | 0 | 0 |
| 0 | 0 | 0 | 0 | 0 | 0 | 0 | 0 |



- Configuration mode will automatically exit as Transparent Mode

|   |   |   |   |   |   |   |   |
|---|---|---|---|---|---|---|---|
| 1 | 0 | 0 | 0 | 0 | 1 | 0 | 0 |
| 0 | 0 | 0 | 0 | 1 | 0 | 1 | 0 |



- Set serial data rate to 38400 bits/sec and press button until *RX* LED lights.

|   |   |   |   |   |   |   |   |
|---|---|---|---|---|---|---|---|
| 1 | 0 | 0 | 0 | 0 | 1 | 0 | 1 |
| 0 | 0 | 0 | 0 | 0 | 0 | 1 | 1 |



- Set radio data rate to 9600 bits/sec and press button until *RX* LED lights.

|   |   |   |   |   |   |   |   |
|---|---|---|---|---|---|---|---|
| 1 | 0 | 0 | 0 | 1 | 0 | 0 | 1 |
| 0 | 0 | 0 | 0 | 0 | 1 | 1 | 1 |



- Set the character type to 7,1,2,E, disabled control, and press button until *RX* LED lights.

Note that as RS485 is used, the CTS/RTS control is disabled.

**Repeater Configuration**

|   |   |   |   |   |   |   |   |
|---|---|---|---|---|---|---|---|
| 0 | 0 | 0 | 1 | 0 | 1 | 0 | 1 |
| 0 | 0 | 0 | 1 | 0 | 1 | 0 | 1 |



- Set the System Address
- Press the red button for approx. 3 seconds - until the *RX* LED comes on.

|   |   |   |   |   |   |   |   |
|---|---|---|---|---|---|---|---|
| 0 | 0 | 0 | 0 | 0 | 0 | 0 | 0 |
| 0 | 0 | 0 | 0 | 0 | 0 | 0 | 0 |



- Configuration mode will automatically exit as Transparent Mode

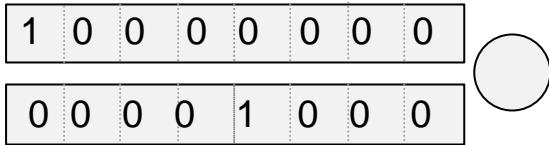

- Set Operating Mode to Transparent Repeater and press button until RX LED lights.

Unit No. 2 Configuration

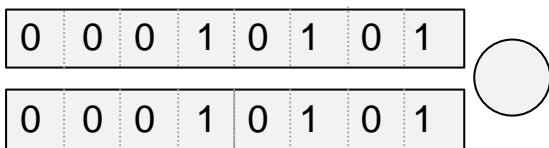

- Set the System Address
- Press the red button for approx. 3 seconds - until the RX LED comes on.

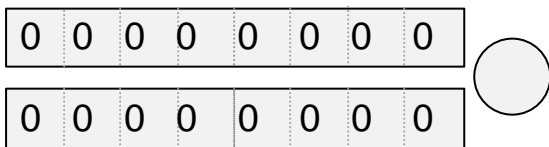

- Configuration mode will automatically exit as Transparent Mode

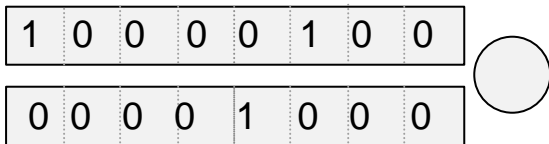

- Set serial data rate to 9600 bits/sec and press button until RX LED lights.

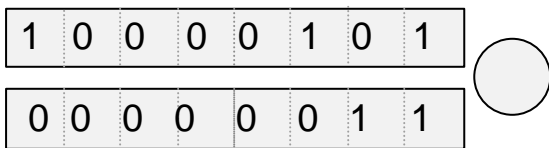

- Set radio data rate to 9600 bits/sec and press button until RX LED lights.

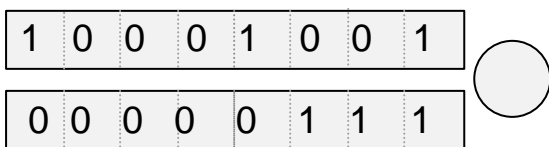

- Set the character type to 7,1,2,E, disabled control, and press button until RX LED lights.  
Note that as RS485 is used, the CTS/RTS control is disabled.

## Appendix B DECIMAL TO BINARY TABLE

| VALUE | 8 BIT PATTERN | VALUE | 8 BIT PATTERN | VALUE | 8 BIT PATTERN |
|-------|---------------|-------|---------------|-------|---------------|
| 0     | 0000 0000     | 38    | 0010 0110     | 76    | 0100 1100     |
| 1     | 0000 0001     | 39    | 0010 0111     | 77    | 0100 1101     |
| 2     | 0000 0010     | 40    | 0010 1000     | 78    | 0100 1110     |
| 3     | 0000 0011     | 41    | 0010 1001     | 79    | 0100 1111     |
| 4     | 0000 0100     | 42    | 0010 1010     | 80    | 0101 0000     |
| 5     | 0000 0101     | 43    | 0010 1011     | 81    | 0101 0001     |
| 6     | 0000 0110     | 44    | 0010 1100     | 82    | 0101 0010     |
| 7     | 0000 0111     | 45    | 0010 1101     | 83    | 0101 0011     |
| 8     | 0000 1000     | 46    | 0010 1110     | 84    | 0101 0100     |
| 9     | 0000 1001     | 47    | 0010 1111     | 85    | 0101 0101     |
| 10    | 0000 1010     | 48    | 0011 0000     | 86    | 0101 0110     |
| 11    | 0000 1011     | 49    | 0011 0001     | 87    | 0101 0111     |
| 12    | 0000 1100     | 50    | 0011 0010     | 88    | 0101 1000     |
| 13    | 0000 1101     | 51    | 0011 0011     | 89    | 0101 1001     |
| 14    | 0000 1110     | 52    | 0011 0100     | 90    | 0101 1010     |
| 15    | 0000 1111     | 53    | 0011 0101     | 91    | 0101 1011     |
| 16    | 0001 0000     | 54    | 0011 0110     | 92    | 0101 1100     |
| 17    | 0001 0001     | 55    | 0011 0111     | 93    | 0101 1101     |
| 18    | 0001 0010     | 56    | 0011 1000     | 94    | 0101 1110     |
| 19    | 0001 0011     | 57    | 0011 1001     | 95    | 0101 1111     |
| 20    | 0001 0100     | 58    | 0011 1010     | 96    | 0110 0000     |
| 21    | 0001 0101     | 59    | 0011 1011     | 97    | 0110 0001     |
| 22    | 0001 0110     | 60    | 0011 1100     | 98    | 0110 0010     |
| 23    | 0001 0111     | 61    | 0011 1101     | 99    | 0110 0011     |
| 24    | 0001 1000     | 62    | 0011 1110     | 100   | 0110 0100     |
| 25    | 0001 1001     | 63    | 0011 1111     | 101   | 0110 0101     |
| 26    | 0001 1010     | 64    | 0100 0000     | 102   | 0110 0110     |
| 27    | 0001 1011     | 65    | 0100 0001     | 103   | 0110 0111     |
| 28    | 0001 1100     | 66    | 0100 0010     | 104   | 0110 1000     |
| 29    | 0001 1101     | 67    | 0100 0011     | 105   | 0110 1001     |
| 30    | 0001 1110     | 68    | 0100 0100     | 106   | 0110 1010     |
| 31    | 0001 1111     | 69    | 0100 0101     | 107   | 0110 1011     |
| 32    | 0010 0000     | 70    | 0100 0110     | 108   | 0110 1100     |
| 33    | 0010 0001     | 71    | 0100 0111     | 109   | 0110 1101     |
| 34    | 0010 0010     | 72    | 0100 1000     | 110   | 0110 1110     |
| 35    | 0010 0011     | 73    | 0100 1001     | 111   | 0110 1111     |
| 36    | 0010 0100     | 74    | 0100 1010     | 112   | 0111 0000     |
| 37    | 0010 0101     | 75    | 0100 1011     | 113   | 0111 0001     |

| VALUE | 8 BIT PATTERN   | VALUE | 8 BIT PATTERN   | VALUE | 8 BIT PATTERN   |
|-------|-----------------|-------|-----------------|-------|-----------------|
| 114   | 0 1 1 1 0 0 1 0 | 151   | 1 0 0 1 0 1 1 1 | 188   | 1 0 1 1 1 1 0 0 |
| 115   | 0 1 1 1 0 0 1 1 | 152   | 1 0 0 1 1 0 0 0 | 189   | 1 0 1 1 1 1 0 1 |
| 116   | 0 1 1 1 0 1 0 0 | 153   | 1 0 0 1 1 0 0 1 | 190   | 1 0 1 1 1 1 1 0 |
| 117   | 0 1 1 1 0 1 0 1 | 154   | 1 0 0 1 1 0 1 0 | 191   | 1 0 1 1 1 1 1 1 |
| 118   | 0 1 1 1 0 1 1 0 | 155   | 1 0 0 1 1 0 1 1 | 192   | 1 1 0 0 0 0 0 0 |
| 119   | 0 1 1 1 0 1 1 1 | 156   | 1 0 0 1 1 1 0 0 | 193   | 1 1 0 0 0 0 0 1 |
| 120   | 0 1 1 1 1 0 0 0 | 157   | 1 0 0 1 1 1 0 1 | 194   | 1 1 0 0 0 0 1 0 |
| 121   | 0 1 1 1 1 0 0 1 | 158   | 1 0 0 1 1 1 1 0 | 195   | 1 1 0 0 0 0 1 1 |
| 122   | 0 1 1 1 1 0 1 0 | 159   | 1 0 0 1 1 1 1 1 | 196   | 1 1 0 0 0 1 0 0 |
| 123   | 0 1 1 1 1 0 1 1 | 160   | 1 0 1 0 0 0 0 0 | 197   | 1 1 0 0 0 1 0 1 |
| 124   | 0 1 1 1 1 1 0 0 | 161   | 1 0 1 0 0 0 0 1 | 198   | 1 1 0 0 0 1 1 0 |
| 125   | 0 1 1 1 1 1 0 1 | 162   | 1 0 1 0 0 0 1 0 | 199   | 1 1 0 0 0 1 1 1 |
| 126   | 0 1 1 1 1 1 1 0 | 163   | 1 0 1 0 0 0 1 1 | 200   | 1 1 0 0 1 0 0 0 |
| 127   | 0 1 1 1 1 1 1 1 | 164   | 1 0 1 0 0 1 0 0 | 201   | 1 1 0 0 1 0 0 1 |
| 128   | 1 0 0 0 0 0 0 0 | 165   | 1 0 1 0 0 1 0 1 | 202   | 1 1 0 0 1 0 1 0 |
| 129   | 1 0 0 0 0 0 0 1 | 166   | 1 0 1 0 0 1 1 0 | 203   | 1 1 0 0 1 0 1 1 |
| 130   | 1 0 0 0 0 0 1 0 | 167   | 1 0 1 0 0 1 1 1 | 204   | 1 1 0 0 1 1 0 0 |
| 131   | 1 0 0 0 0 0 1 1 | 168   | 1 0 1 0 1 0 0 0 | 205   | 1 1 0 0 1 1 0 1 |
| 132   | 1 0 0 0 0 1 0 0 | 169   | 1 0 1 0 1 0 0 1 | 206   | 1 1 0 0 1 1 1 0 |
| 133   | 1 0 0 0 0 1 0 1 | 170   | 1 0 1 0 1 0 1 0 | 207   | 1 1 0 0 1 1 1 1 |
| 134   | 1 0 0 0 0 1 1 0 | 171   | 1 0 1 0 1 0 1 1 | 208   | 1 1 0 1 0 0 0 0 |
| 135   | 1 0 0 0 0 1 1 1 | 172   | 1 0 1 0 1 1 0 0 | 209   | 1 1 0 1 0 0 0 1 |
| 136   | 1 0 0 0 1 0 0 0 | 173   | 1 0 1 0 1 1 0 1 | 210   | 1 1 0 1 0 0 1 0 |
| 137   | 1 0 0 0 1 0 0 1 | 174   | 1 0 1 0 1 1 1 0 | 211   | 1 1 0 1 0 0 1 1 |
| 138   | 1 0 0 0 1 0 1 0 | 175   | 1 0 1 0 1 1 1 1 | 212   | 1 1 0 1 0 1 0 0 |
| 139   | 1 0 0 0 1 0 1 1 | 176   | 1 0 1 1 0 0 0 0 | 213   | 1 1 0 1 0 1 0 1 |
| 140   | 1 0 0 0 1 1 0 0 | 177   | 1 0 1 1 0 0 0 1 | 214   | 1 1 0 1 0 1 1 0 |
| 141   | 1 0 0 0 1 1 0 1 | 178   | 1 0 1 1 0 0 1 0 | 215   | 1 1 0 1 0 1 1 1 |
| 142   | 1 0 0 0 1 1 1 0 | 179   | 1 0 1 1 0 0 1 1 | 216   | 1 1 0 1 1 0 0 0 |
| 143   | 1 0 0 0 1 1 1 1 | 180   | 1 0 1 1 0 1 0 0 | 217   | 1 1 0 1 1 0 0 1 |
| 144   | 1 0 0 1 0 0 0 0 | 181   | 1 0 1 1 0 1 0 1 | 218   | 1 1 0 1 1 0 1 0 |
| 145   | 1 0 0 1 0 0 0 1 | 182   | 1 0 1 1 0 1 1 0 | 219   | 1 1 0 1 1 0 1 1 |
| 146   | 1 0 0 1 0 0 1 0 | 183   | 1 0 1 1 0 1 1 1 | 220   | 1 1 0 1 1 1 0 0 |
| 147   | 1 0 0 1 0 0 1 1 | 184   | 1 0 1 1 1 0 0 0 | 221   | 1 1 0 1 1 1 0 1 |
| 148   | 1 0 0 1 0 1 0 0 | 185   | 1 0 1 1 1 0 0 1 | 222   | 1 1 0 1 1 1 1 0 |
| 149   | 1 0 0 1 0 1 0 1 | 186   | 1 0 1 1 1 0 1 0 | 223   | 1 1 0 1 1 1 1 1 |
| 150   | 1 0 0 1 0 1 1 0 | 187   | 1 0 1 1 1 0 1 1 | 224   | 1 1 1 0 0 0 0 0 |
| 225   | 1 1 1 0 0 0 0 1 | 236   | 1 1 1 0 1 1 0 0 | 247   | 1 1 1 1 0 1 1 1 |
| 226   | 1 1 1 0 0 0 1 0 | 237   | 1 1 1 0 1 1 0 1 | 248   | 1 1 1 1 1 0 0 0 |
| 227   | 1 1 1 0 0 0 1 1 | 238   | 1 1 1 0 1 1 1 0 | 249   | 1 1 1 1 1 0 0 1 |
| 228   | 1 1 1 0 0 1 0 0 | 239   | 1 1 1 0 1 1 1 1 | 250   | 1 1 1 1 1 0 1 0 |
| 229   | 1 1 1 0 0 1 0 1 | 240   | 1 1 1 1 0 0 0 0 | 251   | 1 1 1 1 1 0 1 1 |

| VALUE | 8 BIT PATTERN   | VALUE | 8 BIT PATTERN   | VALUE | 8 BIT PATTERN   |
|-------|-----------------|-------|-----------------|-------|-----------------|
| 230   | 1 1 1 0 0 1 1 0 | 241   | 1 1 1 1 0 0 0 1 | 252   | 1 1 1 1 1 1 0 0 |
| 231   | 1 1 1 0 0 1 1 1 | 242   | 1 1 1 1 0 0 1 0 | 253   | 1 1 1 1 1 1 0 1 |
| 232   | 1 1 1 0 1 0 0 0 | 243   | 1 1 1 1 0 0 1 1 | 254   | 1 1 1 1 1 1 1 0 |
| 233   | 1 1 1 0 1 0 0 1 | 244   | 1 1 1 1 0 1 0 0 | 255   | 1 1 1 1 1 1 1 1 |
| 234   | 1 1 1 0 1 0 1 0 | 245   | 1 1 1 1 0 1 0 1 |       |                 |
| 235   | 1 1 1 0 1 0 1 1 | 246   | 1 1 1 1 0 1 1 0 |       |                 |



UK / Europe Office  
Tel: +44 (0)8700 434040  
Fax: +44 (0)8700 434045  
[info@omniinstruments.co.uk](mailto:info@omniinstruments.co.uk)  
[www.omniinstruments.co.uk](http://www.omniinstruments.co.uk)

Australia / Asia Pacific Office  
Tel +61 (0)282 442 363  
Fax +61 (0)294 751 278  
[info@omniinstruments.com.au](mailto:info@omniinstruments.com.au)  
[www.omniinstruments.com.au](http://www.omniinstruments.com.au)

USA / Canada Office  
Tel +1-866-849-3441  
Fax +1-866-628-8055  
[info@omniinstruments.net](mailto:info@omniinstruments.net)  
[www.omniinstruments.net](http://www.omniinstruments.net)