

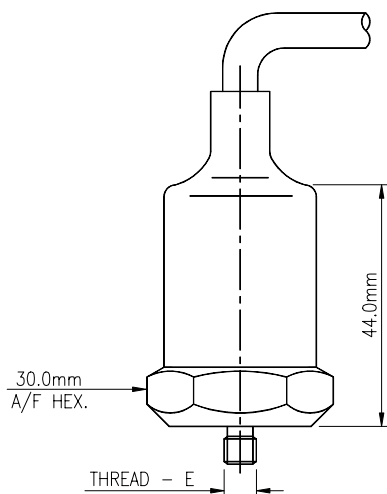

## PZV1 SERIES VELOMETER



- LOW COST
- LIGHT INDUSTRIAL
- INTERNAL AMPLIFIER
- STAINLESS STEEL HERMETICALLY SEALED CASE
- FREQUENCY RANGE 2.5Hz TO 6KHz
- INTERNALLY SHIELDED
- ELECTRICALLY ISOLATED CASE
- FULLY SCREENED

The PZV1 velometer is intended to satisfy the general specification requirements for a low cost vibration transducer for use in multi-point experimental or industrial vibration monitoring applications and is suitable for use with any modern monitoring system, fixed or portable.

The two-wire current-loop operating principle permits very long interconnecting cables to be used where necessary and at minimum expense since standard screened pair (or multi-pair) cables may be used.

The piezo-electric sensor and internal electronics are fully screened within a metal body. The instrument is electrically isolated from its base thus preventing earth loops and eliminating electrical interference. External connections are made via a top exit integral cable unarmoured or armoured, length to be confirmed in metres.

DS1106

# PZV1 VELOMETER

## SPECIFICATION

Operating Voltage/current .....	18 to 28 volts D. C. constant current source of 3.5 to 10mA
Dynamic Range .....	Up to 200g peak (at 24Vdc input)
Frequency Range .....	5Hz to 3.5KHz (better than 1dB) 2.5Hz to 6KHz (better than 3dB)
Transverse sensitivity .....	5%
Amplitude linearity .....	5%
Temperature sensitivity .....	5% over the temp range
Residual electrical noise .....	10 <sup>-4</sup> mm/sec (10Hz)
Signal transmission .....	Two wire system, electrically isolated from base up to 500Vac
Weight.....	200 gms (nominal)

## **Environmental**

Acceleration limit: Vibration .....	200g
Shock .....	500g
Temperature: Operation .....	-25°C to + 80°C
Survival .....	-55°C to + 100°C (short periods)
Protection (BS.EN60529).....	Sealed to IP.66/IP.67

## ORDERING INFORMATION

PZV1 - 

A	B	C	D	E	F	0
---	---	---	---	---	---	---

### A Electrical Configuration

2
---

 - 2 wire ICP device

### D Output & Frequency band

1
---

 4mV/mm/s ± 5%

### B Connection Method

6
---

A
---

 Integral Cable (80°C) Unarmoured

6
---

B
---

 Integral Cable (80°C) Armoured

### C Cable length (Specify in whole metres)

0
---

2
---

 e.g. = 2 metres (max 25 metres)

### E Mounting Thread (Male)

1
---

 - ¼ UNF

2
---

 - M6

3
---

 - M8

4
---

 - Quick Release

### F Hazardous Area Approval

0
---

 - Non Intrinsic