

Shuttle® Level Transmitter



General

Shuttle® is an advanced microprocessor based ultrasonic level meter with a newly developed intelligent, precise measuring system utilizing the latest hardware and software technology.

Shuttle® provides simple and logical operation, using advanced technology resulting in a high quality product at a competitive price.

Shuttle® is designed to measure water levels as well as other fluids and aggressive media, where the ultrasonic sensor is not in contact with the media.

Characteristics

- Ultrasonic measuring system with measuring ranges from 10 cm to 15 metres.
- *Learning*-function allows the Shuttle® Level Transmitter to learn how the tank is arranged with piping, pumps and other items that might disturb the measurement. The system also ignores turbulence and electrical interference, so even a slow moving mixer can pass through the ultrasonic beam without any influence on the measurement.
- 2 output relays for level / system alarm or pump control with duty and standby cycles.
- 4 - 20 mA output with zero and span adjustment.

Operation

Shuttle® needs no operation after initial setup. 9 function buttons behind the front panel are used to configure:

- Unit selection in either metres, centimetres, millimetres, feet and inches.
- Adjustment of zero level of the measurement and selection of relative or absolute reference.
- Zero and span for the mA output.
- Function for the two 2 output relays - off, level alarm, system alarm or pump control with alternation.
- Learning function, so the level meter recognizes how the wetwell is arranged with pumps, piping and other disturbing elements. The measurement will not be affected by false echos.

Control functions

Shuttle® is equipped with 2 output relays which can be configured for level or pump control, system alarm or level alarm. The Control functions relay function

- Indication of the strength of the echo signal with a bar graph.
- Very narrow ultrasonic pulse signal gives great signal strength and minimum sensitivity to foam and sludge on the surface of the liquid.
- Easy to read LCD-display for both set up and indication. Actual level is indicated with both a bar graph and with digits in millimetres, centimetres, metres, feet and inches. The digital readout can be chosen as either relative level or absolute level.
- 10 - 30 V DC or 230 / 115 V AC supply.
- Intrinsically safe ultrasonic sensor (GENELEC Zone 2).

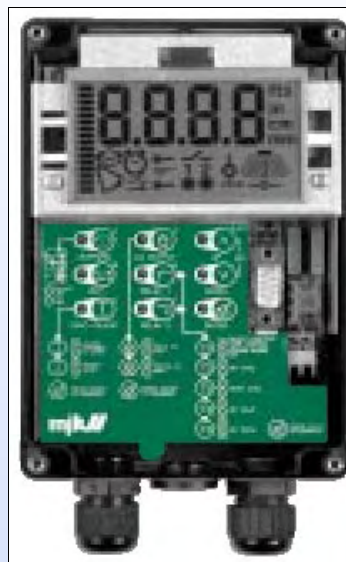

can be set to either NO or NC contact with an optional delay function. The relays can be used for start and stop of pumps with alternation.



Application

Shuttle® is well suited for any ultrasonic level measurement. The level transmitter may also be used for measuring and control of levels in tanks with contaminated and/or aggressive media.

Specifications

Shuttle® Ultrasonic sensor

Range: 15 m
 Frequency: 30 kHz
 Spread: 3 °
 Deadband: 35 cm
 Accuracy: Better than ± 1 mm
 Temperature: - 20 to + 60 °C
 Materials: Polypropylene (grey)
 POM (black)
 Cable: Shielded, oil resistant PVC insulation, length 12 metres. (Max. 100 m. with 690010 cable.)
 Enclosure: IP 68, watertight, withstands max 1 bar submersion.
 CE-approvals: EN 50081-1, EN 50082-1
 Ex-approvals: CENELEC, Zone 2 (EEx nA II T3)

Typical applications is measurement and control in:

- stormflow tanks
- pump stations
- tanks in sewage treatment plants
- tanks in water plants
- tanks and vessels in process- and provisions industries

Shuttle® Converter

Range: 0 - 15 m
 Span: From 0 - 10 cm to 0 - 15 m
 Power supply: 230 / 115 V AC ± 10 %
 10 - 30 V DC
 Consumption: Approx. 2 W
 Temperature: - 20 to + 60 °C
 Input: From ultrasonic sensor
 Accuracy: Better than ± 0.2 %
 Outputs: Analog: 4 - 20 mA, max. load 500 W.
 Digital: 2 x relays with programmable NO/NC function. Max. 50 V, 1 A resistive load.
 Indication: LCD-display with 4 digits and symbols.
 Operation: Function keypad behind front panel.
 Enclosure: IP 65
 CE-approvals: EN 50081-1, EN 50082-1

Electrical connections

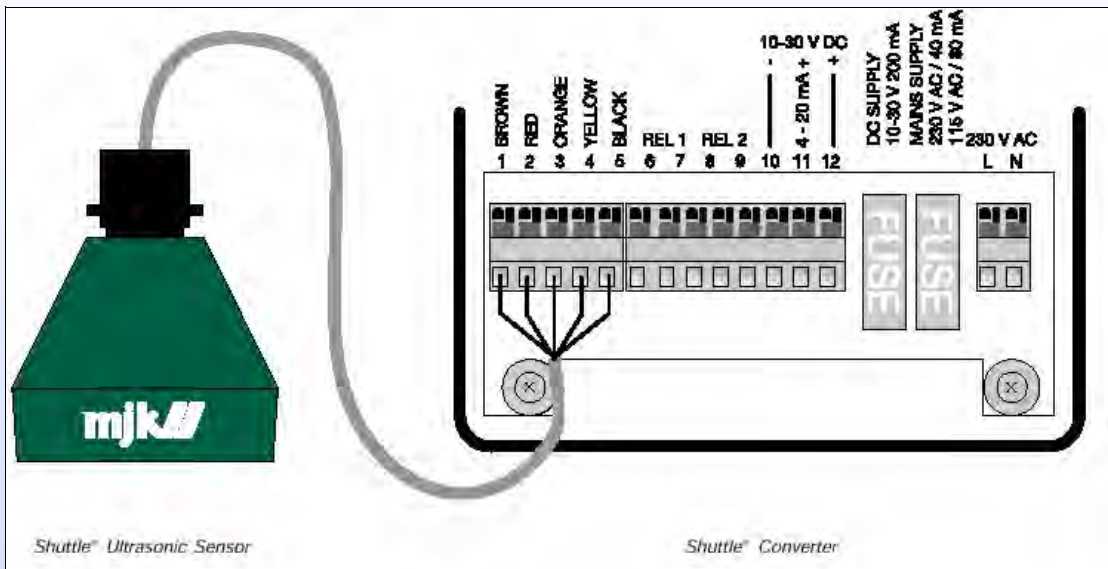



Dimensions

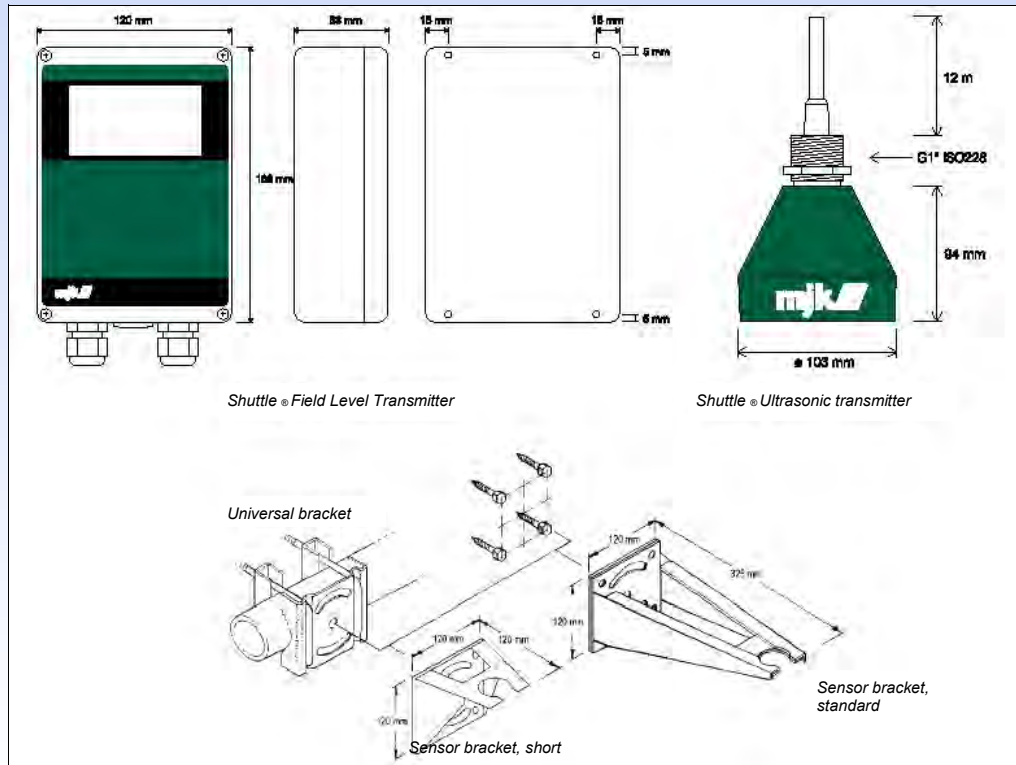

Order numbers

Shuttle ® Field Level Transmitter with Ultrasonic Sensor

201215 Shuttle ® Level Transmitter, complete with Shuttle ® Ultrasonic Sensor and 12 metres of cable, supply voltage 230 / 115 V AC or 10 - 30 V DC

Accessories

200205 Universal bracket
 200219 Short sensor bracket for ultrasonic sensor
 200220 Standard sensor bracket for ultrasonic sensor
 200570 Shuttle ® Ultrasonic Sensor, 30 KHz, complete with 12 metres of cable
 200590 Connection box for sensor cable
 690010 Additional cable for Shuttle ® Ultrasonic Sensor.
 Can be extended to 100 metres, specify length