

INTRODUCTION

The WS10 Web Server is targeted at the acquisition and transmission of data. It is capable of integrating instruments and sensors to the Internet and ethernet. The WS10 comprises an ethernet interface, the TCP/IP protocol, 2 serial communication ports, 2 relay outputs and 4 analog or digital inputs.

The inputs for data acquisition can be either the built-in analog and digital inputs or any inputs from the external equipments connected to the WS10 through the RS485 interface (Modbus protocol).

Data transfer can be accomplished through the ethernet interface or modem (mobile or conventional) using ordinary Internet resources, such as the internet browser, e-mail and TCP connection.



STANDARD APPLICATIONS

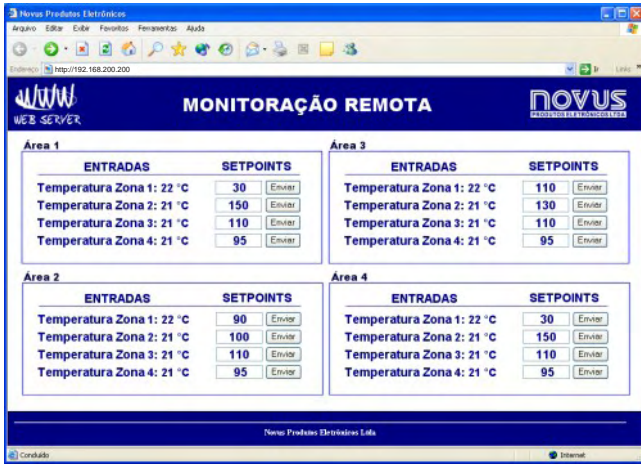

Monitoring processes using Internet browser

The data (from the Webserver analog and digital inputs or from the instruments in the the MODBUS network) is presented as a dynamic HTML page, available to any computer on the network using a standard Internet browser (Netscape, Internet Explorer, etc).

When the Webserver ethernet port is connected to the company's intranet, then any computer in the intranet gains access to the Webserver (password protected) to read and write data do it.

For remote applications, the WS10 connected to a conventional or mobile modem answers a phone call from a dial-up connection and presents the HTML page to the Internet browser of the computer that originated the call, making possible (and easy) the monitoring of remote processes.

Example of application: The WS10 connected to the Novus RHT transmitter measures temperature and humidity. Connected to the ethernet, temperature and humidity values can be seen by any computer within the company.

Unexpected warning by email or mobile phone message

In this application the WS10 monitors the signals on its inputs and on the instruments in the Modbus network and confronts them against user defined preset limits. In the case of an unexpected condition is detected, the Webserver automatically sends e-mails to a mailing list. E-mails are sent through ethernet or modem. Messages sent to mobile phones can be done by e-mail (depending on the routing service provided by the mobile phone operator) or directly by a mobile modem connected directly to the WS10.

Example of application: The WS10 monitors the level of storage tanks and notifies the responsible for stock replacement when the minimum level is reached

INTERNET e ETHERNET

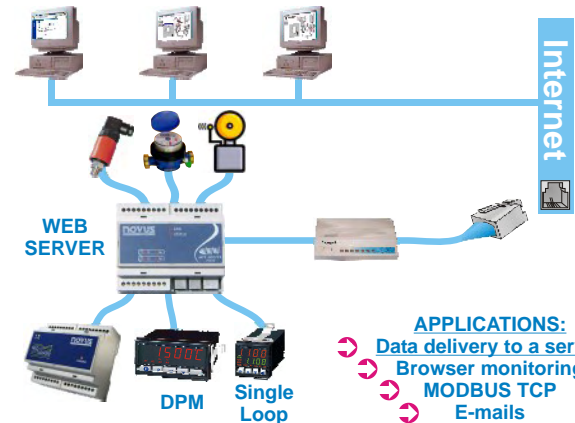

INTERNET WIRELESS GPRS e SMS

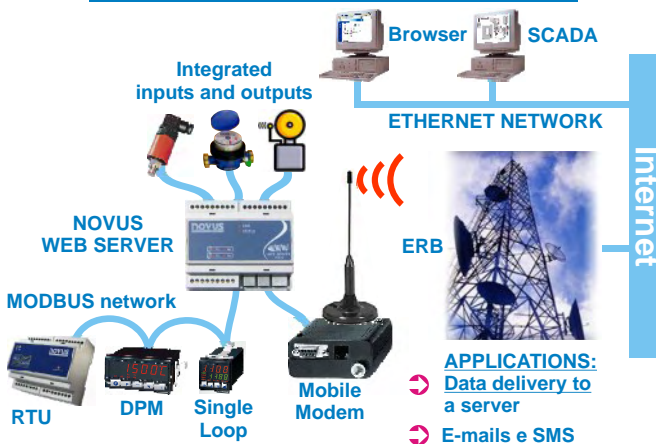

Periodic data send to a remote computer

Recording periodically historical data in a computer is another WS10 function. The value of the monitored variables are stored in the WS10 and periodically sent to any computer accessible to the Webserver, by ethernet or Internet (using a conventional or a mobile modem), where they are received in a TCP connection and stored in a place and format defined by the user

Example of application: The WS10 counts the pulses from the water, gas or energy totalizer devices and sends the data periodically through the Internet by means of a GPRS mobile modem to the computer responsible for generating the bill.

SCADA + Ethernet process supervision

A network of instruments communicating in the Modbus protocol can be easily and efficiently controlled by a SCADA software making use of the protocol Modbus TCP over the Ethernet bus. The WS10 works as a converter and as a temporary data storage (concentrator). Through the RS485 interface, the WS10 monitors continuously the instruments in the Modbus RTU bus, keeping the data in local memory available to immediate access from the Ethernet side. All variables may be read or written in blocks through a single ModbusTCP block command, increasing the efficiency of the communication with the SCADA software, as opposed to ordinary Modbus RTU/TCP converters which don't embed the concentrator capability.

Application example: A group of instruments with Modbus RTU protocol are connected to a RS485 bus. The WS10 acting as a master to the Modbus RTU network, monitors continuously the variables configured in the application. Connected to the corporate Ethernet, the WS10 will serve ModbusTCP requests (reads and writes) to any SCADA workstation that have access to the LAN

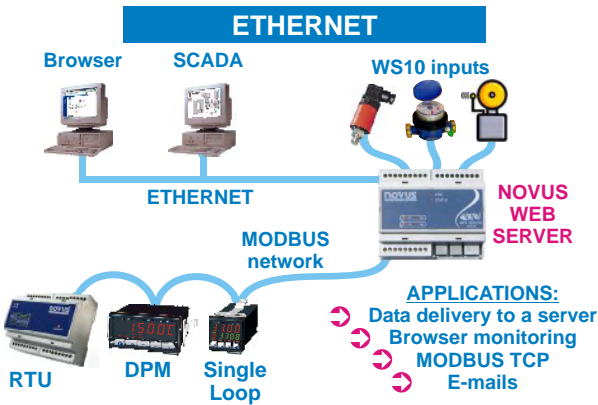

ELECTRICAL CONNECTIONS

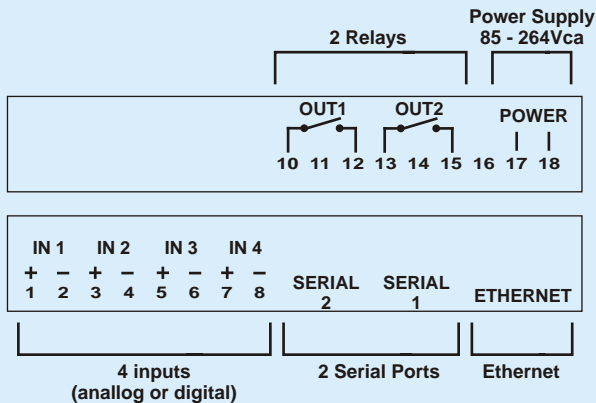

DIMENSIONS

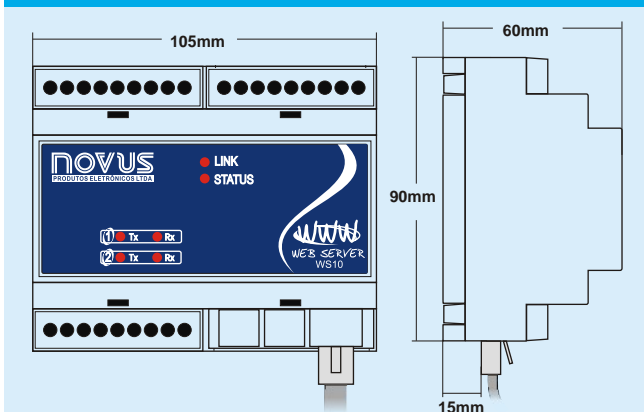

PART NUMBER CREATION

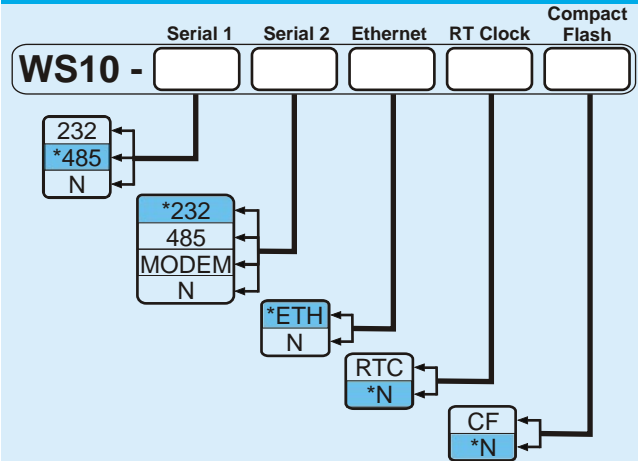

*: Standard configuration.
N: Option not present.

ESPECIFICACIONES

General

Switching power supply, 85 to 250Vac / 4VA.
Operating environment: 0 to 55°C, 35% to 85%RH, no condensation.
ABS housing for DIN rail mount. Dimensions: 105x90x60mm.

Communication Interfaces

Two serial interfaces with 6 pin RJ12 connection. Options:

- RS232.
- RS485 with optical isolation. Modbus RTU master or slave protocol.
- Internal V34+ Modem.

Ethernet 10baseT. RJ45 connection. Protocols: TCP/IP, PPP (client and server), HTTP, FTP, SMTP, DHCP, DNS, ModbusRTU (master and slave), ModbusTCP (server and gateway).

Inputs

Four configurable inputs:

- Digital inputs for voltage pulse or dry contact. Flow measurement and totalizer function.
- Analog inputs for 0 to 5V, 0 to 20mA or 4 to 20mA.

Resolution: 10 bits (1024 levels) for 0 to 5V and 0 to 20mA. 800 levels for 4 to 20mA.
Analog input accuracy: Better than 15mV or 0,06mA.
Pulse flow measurement time base accuracy: Better than 1s.
Pulse input maximum frequency: 200Hz with debounce disabled.
Input impedance: >1M for analog voltage, 230 for current.
Configurable input bias resistor: 10K

Allowable input configurations:

- 4 digital inputs.
- 1 analog and 3 digital inputs.
- 2 analog and 2 digital inputs.
- 4 analog inputs.

Real time clock

Accuracy: ±3 minutes / month @ 25°C.
Battery: CR2032 lithium cell.
Battery life: 10 years.

Memory Expansion

Optional 1M bytes Flash memory expansion.