

Triaxial Magnetometer, Accelerometer & Gyroscope Analog Inertial Sensor

± 150, ±300 or ±1200 °/s
± 2 or ± 5 g
± 1.9 Gauss

FUNCTIONAL DESCRIPTION

The MAG³ is the world's smallest analog inertial measurement unit, providing triaxial analog outputs of acceleration, rate of turn (gyroscope) and magnetic field data. The MAG³ is capable of sensing rotation, acceleration and magnetic field about three orthogonal axes. MAG³ provides all the sensors required for inertial measurement in a single SMT package measuring 0.70 x 0.70 x 0.40 inches.

Temperature outputs are also provided allowing the implementation of compensation techniques. A self-test feature can be used to actuate the gyro and accelerometer sensing structures and associated electronics. The MAG³ magnetic sensor reset feature can be used to periodically condition the magnetic sensor for optimum performance.

FEATURES

- Triaxial Gyroscope
- Triaxial Accelerometer
- Triaxial Magnetometer
- Solid-State MEMS Reliability
- Low Noise
- Low Power
- SMT Miniature Package
- 2000g Powered Shock Operation
- 5 V Single Supply Operation

ORDERING INFORMATION

Part	Accelerometer (g)	Rate (°/s)
MAG02-0150S050	± 2	± 150
MAG05-0150S050	± 5	± 150
MAG02-0300S050	± 2	± 300
MAG05-0300S050	± 5	± 300
MAG02-1200S050	± 2	± 1200
MAG05-1200S050	± 5	± 1200

APPLICATIONS

- Antenna Stabilization
- Inertial Measurement Units
- Automotive Control
- Attitude Referencing
- Orientation Sensing
- 3D Simulators
- Industrial Automation

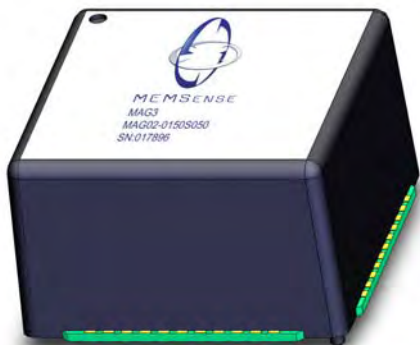

ORIENTATION DIAGRAM

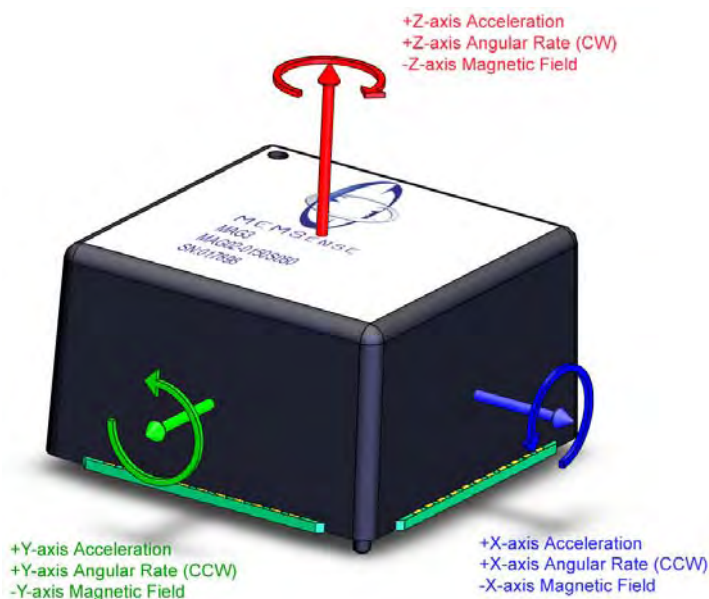

Triaxial Magnetometer, Accelerometer & Gyroscope Analog Inertial Sensor

± 150, ±300 or ±1200 °/s
± 2 or ± 5 g
± 1.9 Gauss

Table 1 – Specifications

Parameter	Specification			Units	Conditions
Sensor					
Operating Voltage Range	4.75 to 5.25			V	
Supply Current	51, (57)			mA	Typical, (Maximum)
Mass	5			Grams	Maximum
Commercial Temperature Range					
	0 to +70			°C	Temperature for max and min specs.
Military Temperature Range					
	-40 to +85			°C	Temperature for max and min specs.
Accelerometers					
	MAG02		MAG05		
Range	± 2		± 5	g	
Sensitivity	1000		400	mV/g	Ratiometric to supply voltage
Offset Vs Temp	±150		± 60	mV	0 to 70 °C
Noise X and Z	35		35	µg/Hz ^½	
Noise Y	65		65	µg/Hz ^½	
Bandwidth ¹	50		50	Hz	Factory set 3dB point
Nonlinearity	± 0.4, (± 1.0)		± 0.4, (± 1.0)	% of FS	Typical, (Maximum)
Cross Axis Sensitivity	2		2	%	
Rate Output					
	0150S050	0300S050	1200S050		
Dynamic Range	±150	± 300	±1200	°/s	Full scale range over specified temperature
Sensitivity	12.5	5.0	1.25	mV/°/s	
Nonlinearity	0.1	0.1	0.1	% of FS	Best fit straight line
Zero Rate	2.50	2.50	2.50	V	
Turn On Time	35	35	35	ms	Power on to ± ½ °/s of Final
Rate Noise Density	0.05	0.1	0.1	°/s/Hz ^½	
Bandwidth ¹	50	50	50	Hz	Factory set 3dB point
Cross Axis Sensitivity	1	1	1	%	
Rate Reference Output					
Voltage Value	2.5			V	
Power Supply Rejection	60			db	4.75 Vs to 5.25 Vs
Temperature Drift	5.0			mV	Deviation from 25°C
Temperature Output					
Voltage at 25 °C	2.50			V	
Scale Factor	8.4			mV/°C	
Magnetic Field					
Dynamic Range	± 1.9			gauss	
Sensitivity Drift	2700			ppm/°C	
Sensitivity	1.0			V/gauss	
Nonlinearity	0.5			% of FS	Best fit straight line
Noise Density	68			nV/Hz ^½	
Bandwidth ²	50			Hz	Magnetic signal
Cross Axis Sensitivity	3			%	
Absolute Maximum Ratings					
Acceleration Powered	2000 max			g	Any axis 0.5ms
Vdd	-0.3, +6.0			V	Minimum, Maximum
Operating Temperature	-40 to +85			°C	
Storage Temperature	-65 to +150			°C	

Typical Values at 25 °C, Vdd = 5.0V, 0 °/s unless otherwise noted

- Other bandwidth configurations are available upon request.
- Addition of external 2.2µF capacitor to ground sets each magnetic signal's bandwidth to 50Hz. $F_{3dB} = 1/(2 * \pi * 1.5k * C)$

Triaxial Magnetometer, Accelerometer & Gyroscope Analog Inertial Sensor

± 150, ±300 or ±1200 °/s
± 2 or ± 5 g
± 1.9 Gauss

Table 2 - Pin Function Descriptions

Pin No.	Name	Function
1	XREF	X axis analog precision reference output.
2	XRATE	X axis analog rate signal output.
3	ZREF	Z axis analog precision reference output.
4	ZRATE	Z axis analog rate signal output.
5	TEMPZ	Analog temperature voltage output, Z gyro.
6	AGND	Analog power supply return.
7	TEMPX	Analog temperature voltage output, X gyro.
8	TEMPY	Analog temperature voltage output, Y gyro.
9	XMAG	X axis differential analog magnetic signal output
10	YMAG	Y axis differential analog magnetic signal output
11	ZMAG	Z axis differential analog magnetic signal output
12-22		No connect (open) ¹
23	MGND	Magnetic sensor reset circuit ground
24	MAG RESET	Magnetic reset input
25	MGND	Magnetic sensor reset circuit ground
26	VDDM	Magnetic sensor reset power supply
27-35		No connect (open) ¹
36	AGND	Analog power supply return.
37	VDDA	Analog power supply.
38	TESTN	High-level activated digital input stimulating X, Y and Z rate to Ref - 660mV. ²
39	TESTP	High-level activated digital input stimulating X, Y and Z rate to Ref +660mV. ²
40	YACCEL	Y axis analog acceleration signal output.
41	ZACCEL	Z axis analog acceleration signal output.
42	XACCEL	X axis analog acceleration signal output.
43	YREF	Y axis analog precision reference output.
44	YRATE	Y axis analog rate signal output.

1. Physical solder connection recommended.
2. The 300°/s and 1200°/s rate sensor will produce a 270 mV and 67.5 mV output change respectively.

Figure 1 – AccelRate3D Physical Dimensions

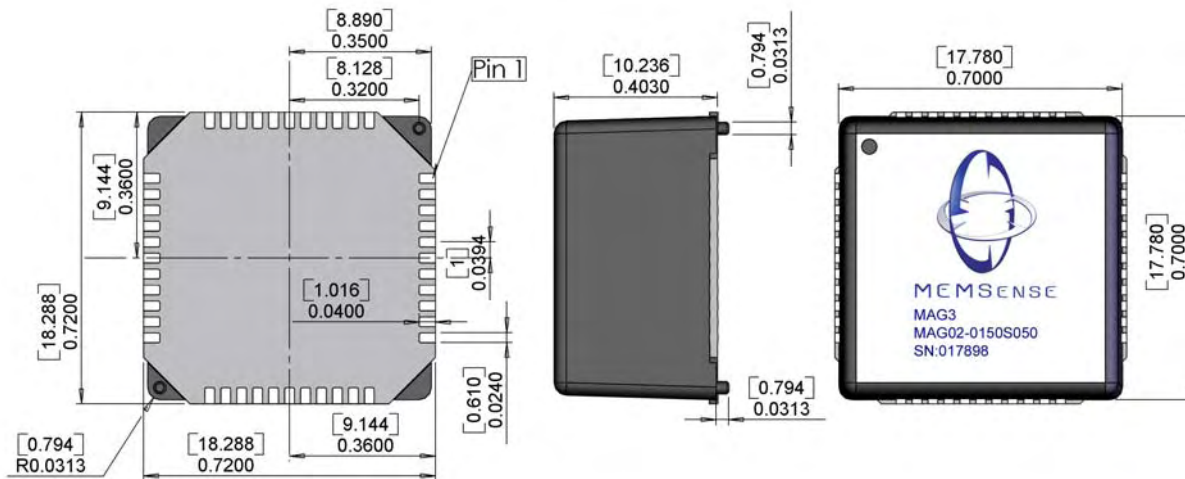

All dimensions in [mm] inches - Hand solder attachment recommended