

Schaevitz LSOP/LSOC Gravity-Referenced Inclinometer

Features

- Fully self-contained - connect to a DC power source and a readout or control device for a complete operating system
- High-level DC output signal or 4-20mA proportional to sine of the angle of tilt
- $\pm 1^\circ$ to $\pm 90^\circ$ ranges available
- Extremely rugged, withstands 1500g shock

Applications

- Bore-hole mapping, dam and rock shifts and other geophysical, seismic and civil engineering studies
- Ballast transfer systems for offshore barges, ships and other marine applications
- Level control and calibration systems
- Pipeline levelling, setting tilt of grading machines, crane overturning-moment alarms, and other heavy duty construction control requirements
- Large machinery installation and other electronic level applications



LSOC/LSOP

The LSO Series is a high precision gravity referenced tilt sensor that can be used for a wide variety of commercial and aerospace applications. Models are available in a variety of ranges with low impedance output signal. Electrical terminations are via 6-way connector or solder pins.

4-20 mA Output

The LSO 4-20 mA, 3-wire output design is specifically designed for electrically noisy environments or where the inclinometer output signal must travel a long distance. The inclinometer operates on a single 24 VDC supply and the output series load resistance can be as high as 400 Ω . The output current is proportional to the sine of the tilt angle.

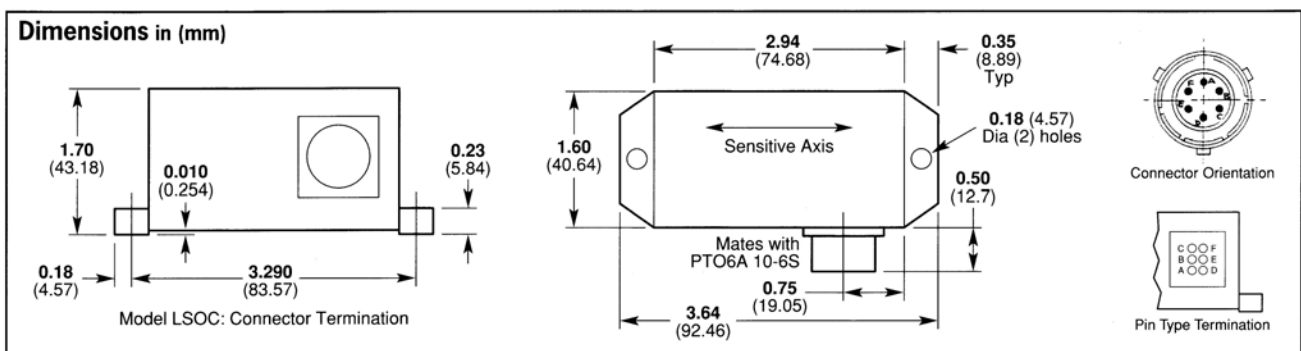

Schaevitz LSOP/LSOC Gravity-Referenced Inclinometer

Environmental Characteristics

Operating Temperature Range	°C	-18 to 70
Survival Temperature Range	°C	-40 to 70
Constant Acceleration Overload	g	50
Shock Survival		1500g, 0.5msec, ½ sine
Vibration Endurance		35g rms, 20 Hz to 2000 Hz sinusoidal
Environmental Sealing		IP65

Specifications by Range @ 20°C

Range		±1°	±3°	±14.5°	±30°	±90°
Excitation Voltage	Volts dc	±12 to ±18 (20 to 30 for 4-20mA option)				
Current Consumption	mA (nom)	±15 (35 for 4-20mA option)				
Full Range Output (FRO) (see note 1)	Volts dc	±5 (4 to 20 mA for 4-20mA option)				
Output Standardisation	% FRO	±1				
Output Impedance	Ω	less than 10				
Output Noise	V rms (max)	0.002 (10 uA for 4-20mA option)				
Non-Linearity (see note 2)	% FRO (max)	0.05	0.05	0.02	0.02	0.05
Non-Repeatability	% FRO (max)	0.04	0.02	0.004	0.002	0.001
Resolution	arc seconds	0.1	0.2	1.0	2.0	4.0
-3 dB Frequency	Hz	0.5	2	15	20	40
Sensitive Axis-to-Case Misalignment	deg (max)	±0.1	±0.15	±0.25	±0.5	±1.0
Cross-axis sensitivity (see note 3)	% FRO (max)	0.1				
Zero Offset (see note 4)	Volts dc (max)	±0.05	±0.04	±0.03	±0.02	±0.02
Thermal Zero Shift	%FRO/°C (max)	0.05	0.03	0.01	0.005	0.003
Thermal Sensitivity	%Reading/°C (max)	0.04	0.03	0.01	0.006	0.006

Notes

1. Full Range Output is defined as the full angular excursion from positive to negative, i.e. ±90° = 180°
2. Non-linearity is determined by the method of least squares and the largest error value is reported
3. Cross-axis Sensitivity is the output of unit when tilted to full range angle in cross-axis.
4. Zero offset is specified under static conditions with no vibration inputs

How to Order

Specify model type with appropriate range e.g. LSOC-14.5
 For 4-20mA option suffix range with 4-20 e.g. LSOC-14.5-4-20



UK / Europe Office
 Tel: +44 (0)8700 434040
 Fax: +44 (0)8700 434045
info@omniinstruments.co.uk
www.omniinstruments.co.uk

Australia / Asia Pacific Office
 Tel +61 (0)282 442 363
 Fax +61 (0)294 751 278
info@omniinstruments.com.au
www.omniinstruments.com.au

USA / Canada Office
 Tel +1-866-849-3441
 Fax +1-866-628-8055
info@omniinstruments.net
www.omniinstruments.net