

VPFlowMate probe



Description

The VPFlowMate[®] probe is an easy to install solution for many flow metering applications.

The VPFlowMate[®] connects directly to a PC and most analogue and industrial equipment. An optional integrated display is provided for direct readout of flow and total volume.

Applications

Compressed air metering, energy monitoring, testing of pneumatic systems. Take a look at the application examples for more ideas!

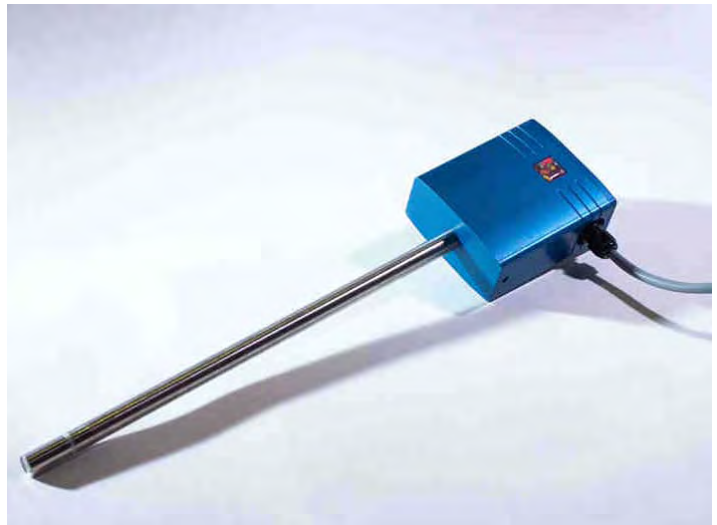

Benefits

- Versatile: for various pipe sizes
- Universal: Data output via RS232, 4..20 mA, pulse and optional display
- Easy: Straightforward installation and use

Features

- Silicon (solid state) flow sensor
- 12..24 Volt wide range power input
- Flow and totalizer readout via RS232
- Optional linear flow signal via 4..20 mA
- Optional pulse output
- Optional built-on 8 x 2 LCD display
- Configurable via easy to use software

VFlowMate probe



Specifications

Measurement

Typical accuracy* :	Better than 0.5% of full scale*
Reproducibility :	< 0.5% of measured value per year
Ranges :	0..150 m _n / sec (m _n is referenced to 0°C Celsius, 1013.25 mbar) 0...80 m _n / sec 0...20 m _n / sec
Zero cutoff point :	Depends on model; typically 1 to 2% of full scale
Temperature range** :	0..50 °C.
Pressure limit :	16 bar maximum pressure***
Humidity range :	Up to 95% Relative Humidity, non condensing
Gases :	Compressed Air, Nitrogen, non corrosive gasses

Mechanical

Connections :	Connected with 0,5" compression fitting
Dimensions :	Refer tot technical drawings
Protection type :	Designed to meet IP 65
Housing material :	Aluminium, painted
Wetted materials :	Epoxy, glass, stainless steel 316
Corrosion resistance :	Highly corrosive or acid environments should be avoided

Electrical

Outputs :	RS232, 4..20 mA, pulse
Power supply :	12..24 Volt DC +/- 10%
Connections :	Multi pole connector

Approvals/ conformity

CE :	EN 61326-1
CE :	EN 50082-1
CUL :	14 AZ, Industrial Control Equipment

DISCLAIMER:

Specifications in this brochure are indicative and subject to change without prior notice.

* NOTE:

This level of accuracy can only be reached in ideal situations, where the flow profile is uniform and fully developed. Installation effects will cause

** NOTE:

The temperature error is typically less than 0.2% per degree Celsius.

*** NOTE:

The pressure error is typically 0.3% per bar deviation of the calibration pressure.



VPFlowMate probe



Select the right VPFlowMate insertion probe for your application!

For successful use, you should at least go through the following checklist; you should also complete our standard order form (ask your sales engineer), to make sure that all application data are taken into account!

1. Determine expected flow range (min. and max. flow in m^3/hr).
2. Determine the pipe diameter (in mm).
3. Determine the velocity in m_n/sec using Figure 1.
4. Select your probe .

For the next step, see the order configuration table on page 6.

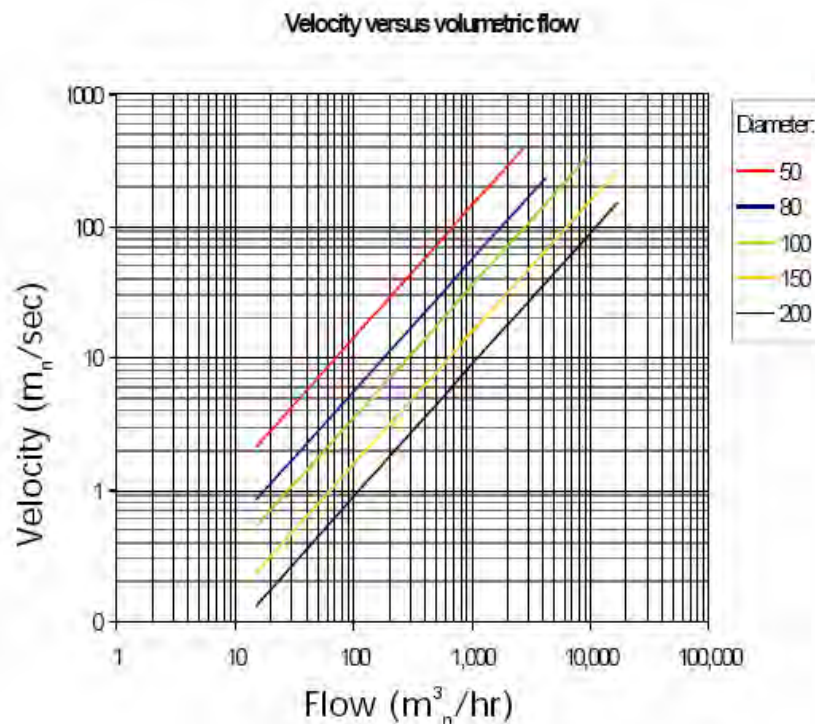

Fig. 1. Velocity vs volumetric flow graph

In this figure you can roughly determine the velocity (in normal meters per second) for a given pipe diameter (in mm) and flow rate (in normal cubic meters per hour). This figure can be used to select the right model for your application.

VFlowMate probe



Features and benefits

Software configurable
For optimal flexibility.
Adapt to installation conditions

Versatile outputs
RS232, 4..20 mA (linear), pulse

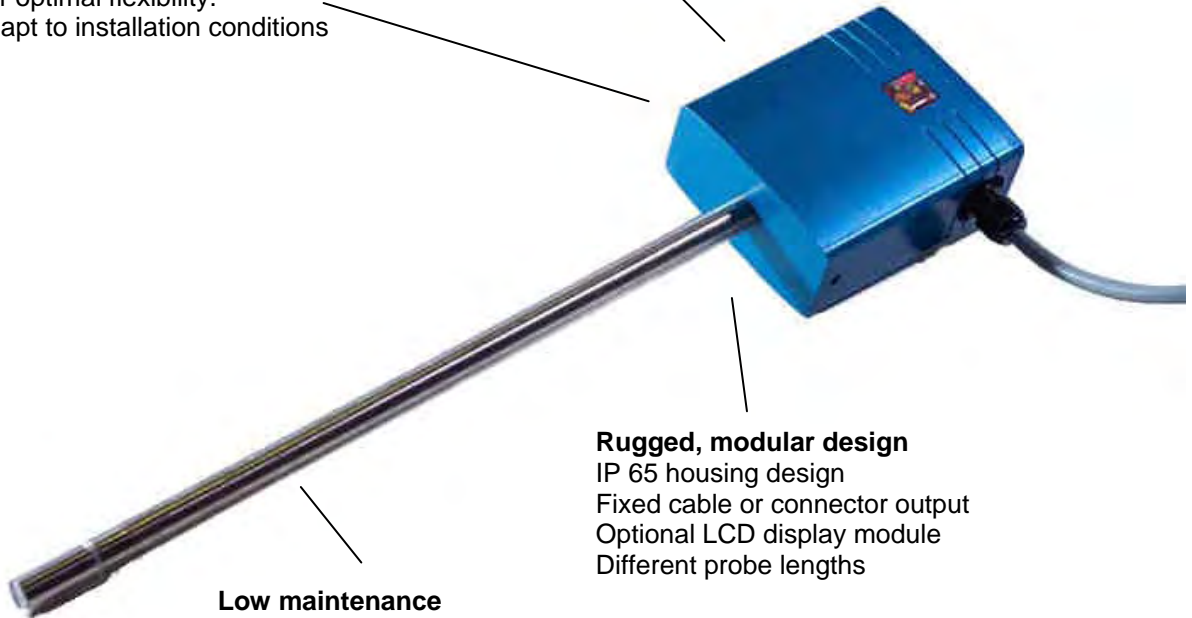

Rugged, modular design
IP 65 housing design
Fixed cable or connector output
Optional LCD display module
Different probe lengths

Low maintenance
Rugged sensor
Easy cleanable
Long re-calibration interval

Built-on display option

Features flow and totalizer readout

- Direct readout of flow
- Direct readout of total consumption
- Clear back-lit display



VFlowMate probe



Dimensional drawings

Standard version

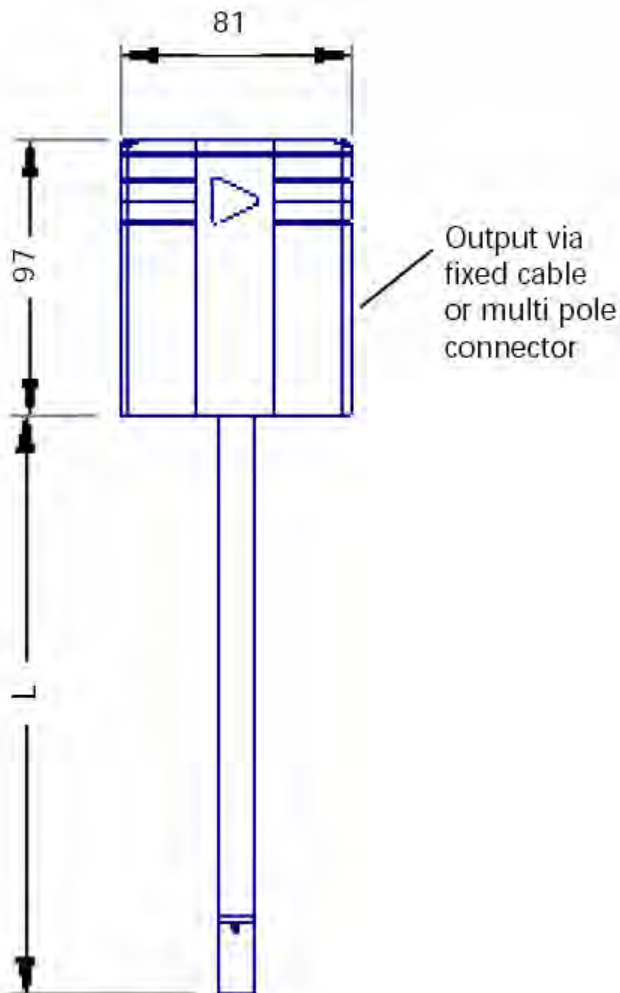

Optional display module

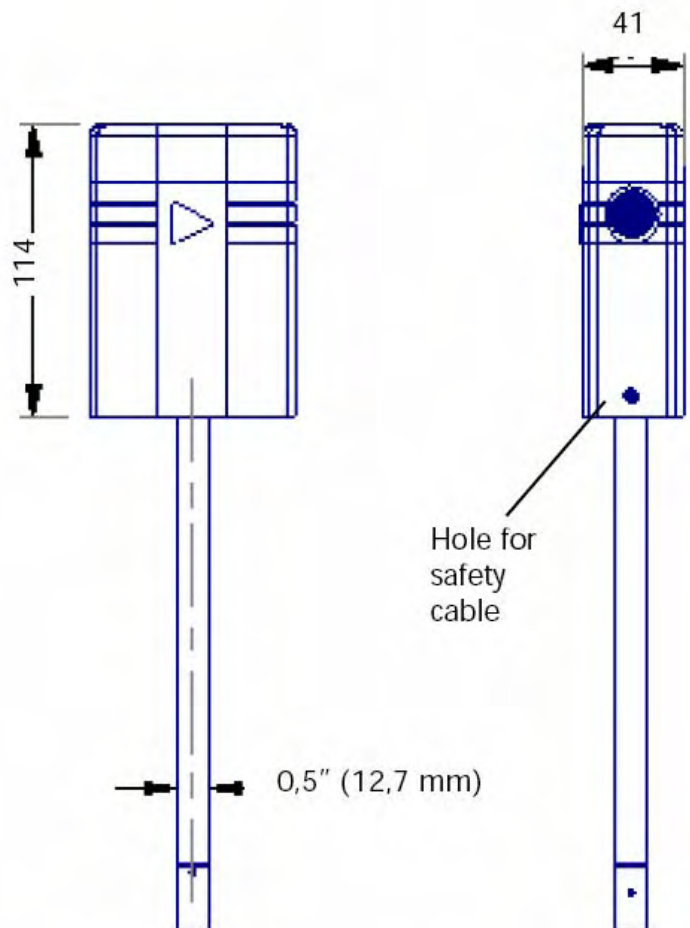

Probe length table

Type	Length [L]
P300	300 mm
P400	400 mm
P600	600 mm

VFlowMate probe



Order configuration table

1. Group	2. Range	3. Probe length
-------------	-------------	-----------------------

A. LCD	B. Outputs	C. Connec- tor
-----------	---------------	----------------------

VPP

R150

P300

D1

S010

E200

No.	Item	Code	Description
Measurement:			
1.	Product group	VPP	Insertion probe
2.	Range	R150 R080 R020	0..150 m _n /sec 0..80 m _n /sec 0..20 m _n /sec
3.	Probe length	P300 P400 P600	Length = 300 mm Length = 400 mm Length = 600 mm
Outputs:			
A.	Display options	D0 D1	No display LCD display, flow and totalizer (digital)
B.	Output options	S010 S110	4..20 mA linear output 4..20 mA output + pulse output
C.	Connector options	E200 E304 E310	Multi pole connector, including male connector and 4 m cable with stripped wire ends Fixed cable, 4 m Fixed cable, 10 m

VFlowMate is a registered trademark of Van Putten Instruments B.V. Patents have been applied for and are pending.