

AV-DSP

Single point air velocity transmitter

Technical Overview

The new **AV-DSP** is a single point, multi-range air velocity transmitter with user selectable 0-10Vdc or 4-20mA outputs and 4 user selectable measurement ranges. The unit has a built-in self test feature and the user can manually override the output to 0%, 50% or 100% of output range to aid commissioning.

A flange plate (**DPA**) is available for adjustment of the penetration depth.



Features

- User selectable 0-10Vdc or 4-20mA outputs
- Built-in self-test feature
- Durability and resistance to chemical reagents
- Built-in manual override facility for 0%, 50% or 100% of output range

Specification

Output ranges:

- 0 to 4 m/s
- 0 to 8 m/s
- 0 to 16 m/s
- 0 to 32 m/s

Accuracy ($\pm 3\%$ of range):

- 0 to 4 m/s ± 0.12 m/s
- 0 to 8 m/s ± 0.24 m/s
- 0 to 16 m/s ± 0.48 m/s
- 0 to 32 m/s ± 0.96 m/s

Output:

- 4-20mA, 100 Ω loop resistance min
- 0-10Vdc into 4.7k Ω min

Supply (current output):

- 20Vdc to 35Vdc for 500 Ω loop resistance
- 12Vdc to 30Vdc for 100 Ω loop resistance

Supply (Voltage output):

- 17Vdc to 34Vdc
- 14Vac to 26Vac supply into 4.7k Ω min

Max. current 50mA

Ambient temp range -10°C to $+50^{\circ}\text{C}$

Housing:

- Material Flame retardant ABS
- Dimensions 55mm x 90mm dia.

Probe:

- Material Delrin
- Dimensions 240mm x 19mm dia.

Protection IP65

Country of origin EU

Product Codes

AV-DSP

Single point multi-range air velocity transmitter

Single point air velocity transmitter

Installation

Transmitters should only be fitted to a system after airflow calibration has been carried out and preferably following full fan running of at least several days, in order that the main contaminants have been removed from the stagnant system.

1. Select a location in the duct where dust & contaminants are at a minimum.
2. If the sensor is to be mounted outside, it is recommended that the unit be mounted with the cable entry at the bottom. If the cable is fed from above then into the cable gland at the bottom, it is recommended that a rain loop be placed in the cable before entry into the sensor.
3. Drill two holes at 85mm centres, and a 19mm diameter hole centrally between them for the duct probe. fix the IP65 housing to the duct with appropriate screws. Making sure to align the holes in the probe so they point into the air flow. The housing is designed to make it easy for an electric screwdriver to be used if desired.
4. Remove the front cover by twisting the lid and separating from the main body.
5. Feed the cable through the waterproof gland and terminate the cores at the terminal block. Leaving some slack inside the unit, tighten the cable gland onto the cable to ensure watertightness.
6. Replace the lid after the electrical connections have been made.
7. Ensure that the supply voltage is within the specified tolerances.
8. It is recommended that screened cable be used and that the screen should be earthed at the controller. Care should be taken not to lay control signal wiring in close proximity to power or other cables which may produce significant electromagnetic noise.
9. Allow 3 minutes before checking functionality.
10. Allow 30 minutes before carrying out pre-commissioning checks.

Installation notes

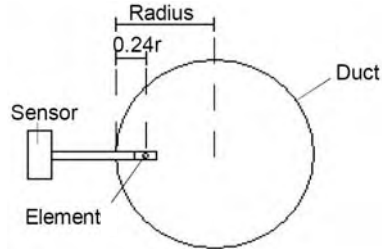

1. The **AV-DSP** should be installed not less than 2 metres downstream from any heating or cooling devices, source of moisture such as humidifier, fan or bend in the duct-work.
 2. To ensure accurate readings the **AV-DSP** should be installed so that the element is 0.24 x the duct radius into the duct.
 3. Reading errors of up to 30% may be experienced if the elements are positioned in the centre of the duct.
 4. The **AV-DSP** should be mounted with the holes in the end of the probe orientated directly into the air flow, to allow full air flow over the sensing element.
 5. The **AV-DSP** requires approx. 50mA. Ensure the supply to the sensor is capable of providing this current.
 6. If using a current output mode, the sensor must only be used with a 24V DC supply. The sensor may be damaged if supplied with AC.
- Note:** When using current output mode they are NOT loop powered and will require a common 0V connection.

Single point air velocity transmitter

Connections

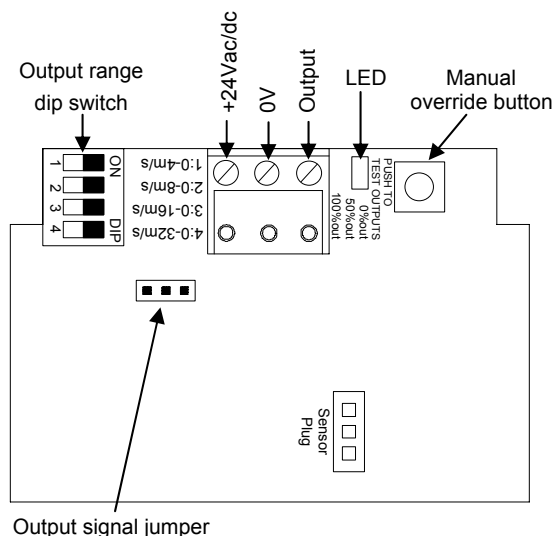

Current output

If using a current output mode, the sensor must only be used with a 24V DC supply. The sensor may be damaged if supplied with AC.

Note: When using current output mode they are NOT loop powered and will require a common 0V connection.

Jumper settings

Output signal



Output range selection

Output range	Dip sw itch			
	1	2	3	4
0 to 4m/s	ON	OFF	OFF	OFF
0 to 8m/s	OFF	ON	OFF	OFF
0 to 16m/s	OFF	OFF	ON	OFF
0 to 32m/s	OFF	OFF	OFF	ON

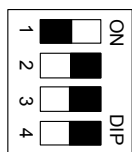

Example:
Output range selected 0 to 4m/s.

Self-test & manual override mode

The output of the **AV-DSP** can be manually overridden to one of 3 values by pressing the PCB mounted button. When this button is pressed once, the output will change to 0% of the output's range, when pressed again the output will change to 50% of the output's range and when pressed a third time will change the outputs to 100% of the outputs range. Pressing again will return the outputs to automatic control.

Example:

- First Press – Velocity output falls to 0%, LED flashes slowly
- Second Press – Velocity output rises to 50%, LED flashes slowly
- Third Press – Velocity output rises to 100%, LED flashes slowly
- Fourth Press – Velocity output reverts to automatic levels. The LED should be permanently on.

Failure Mode

If the sensor element assembly is damaged, the output will change to the following fixed default value and the LED will flash rapidly;

Velocity = 0%

Trend scaling

4-20mA (0 to 4 m/s)		(0 to 8 m/s)	
Brange	-6	Brange	-12
Trange	4	Trange	8
Upper	4	Upper	8
Lower	0	Lower	0
Exp	2	Exp	2
 (0 to 16 m/s)		 (0 to 32 m/s)	
Brange	-24	Brange	-48
Trange	16	Trange	32
Upper	16	Upper	32
Lower	0	Lower	0
Exp	2	Exp	3

Single point air velocity transmitter

Trend scaling (continued)

0-10Vdc

(0 to 4 m/s)		(0 to 8 m/s)	
Brange	-4	Brange	-8
Trange	4	Trange	8
Upper	4	Upper	8
Lower	0	Lower	0
Exp	2	Exp	2

(0 to 16 m/s)		(0 to 32 m/s)	
Brange	-16	Brange	-32
Trange	16	Trange	32
Upper	16	Upper	32
Lower	0	Lower	0
Exp	2	Exp	2

IQ2xx and IQ3 series (with type 5, characterise),

4-20mA

(0 to 4 m/s)		(0 to 8 m/s)	
Upper	4	Upper	8
Lower	0	Lower	0
Exp	2	Exp	2
Points used	2	Points used	2
I1	4	I1	4
O1	0	O1	0
I2	20	I2	20
O2	4	O2	8

(0 to 16 m/s)		(0 to 32 m/s)	
Upper	16	Upper	32
Lower	0	Lower	0
Exp	2	Exp	2
Points used	2	Points used	2
I1	4	I1	4
O1	0	O1	0
I2	20	I2	20
O2	16	O2	32

0-10Vdc

(0 to 4 m/s)		(0 to 8 m/s)	
Upper	4	Upper	8
Lower	0	Lower	0
Exp	2	Exp	2
Points used	2	Points used	2
I1	0	I1	0
O1	0	O1	0
I2	10	I2	10
O2	4	O2	8

(0 to 16 m/s)		(0 to 32 m/s)	
Upper	16	Upper	32
Lower	0	Lower	0
Exp	2	Exp	2
Points used	2	Points used	2
I1	0	I1	0
O1	0	O1	0
I2	10	I2	10
O2	16	O2	32